

# ASSEMBLY INSTRUCTIONS MANUAL DE MONTAGEM / INSTRUCCIONES DE ARMADO

FOSTER OFFICE TABLE  
MESA FOSTER  
ESCRITORIO FOSTER

Reference  
Referência  
Referencia

210091

Revise  
Revisão  
Revisión

00

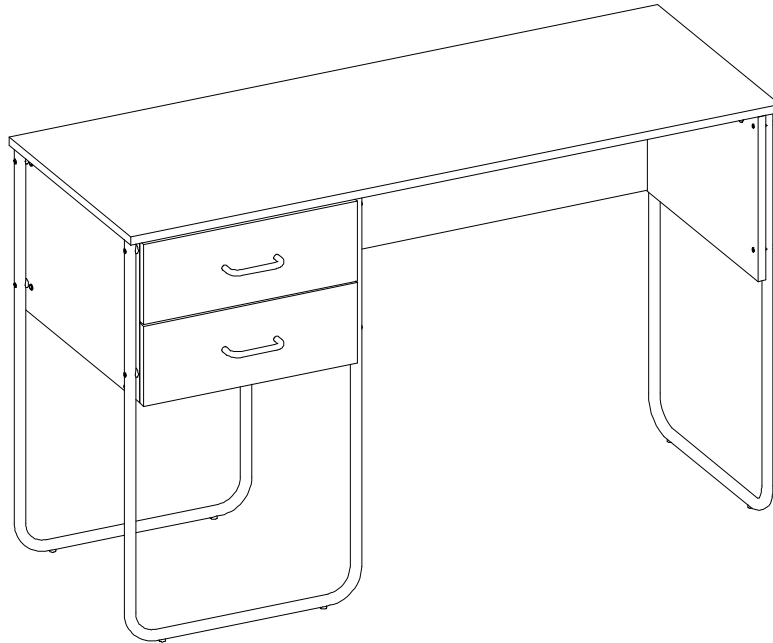

## YOU WILL NEED / VOCÊ VAI PRECISAR DE / USTED NECESITARÁ

Tools not supplied / Ferramentas não fornecidas / Herramientas no incluidas

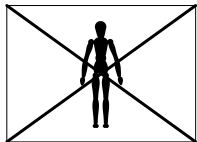

1 Person  
1 Pessoa  
1 Persona

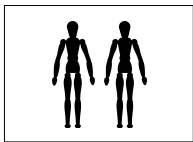

2 People  
2 Pessoas  
2 Personas

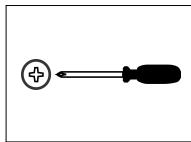

Screwdriver Phillips  
Chave Phillips  
Destornillador cruz

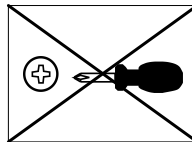

Small screwdriver Philips  
Chave Phillips menor  
Destornillador cruz menor

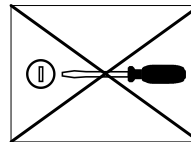

Screwdriver slotted  
Chave fenda  
Destornillador plano

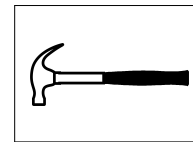

Hammer  
Martelo  
Martillo

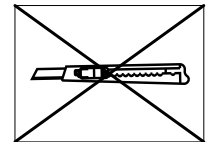

Stylet  
Estilete  
Estilete

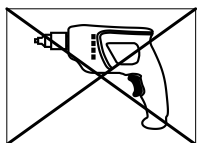

Drill machine  
Furadeira  
Taladro

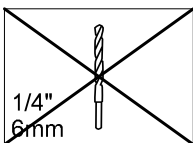

1/4"  
6mm  
Drill bit  
Broca  
Taladro

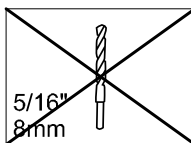

5/16"  
8mm  
Drill bit  
Broca  
Taladro

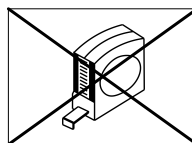

Measuring tape  
Trena  
Cinta de medición

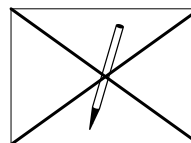

Pencil  
Lápis  
Lápiz

**NOTES:** The separation of the accessories before you start the assembly will facilitate the same. In case of doubt on the size of the screws and bolts, use the ruler to bottom of page 3.

**NOTAS:** A separação dos acessórios antes de iniciar a montagem facilitará a mesma. Em caso de dúvida no tamanho dos parafusos e cavilhas, utilize a régua ao final da página 3.

**NOTAS:** La separación de los accesorios antes de comenzar el armado facilitará el mismo. En caso de duda sobre el tamaño de los tornillos y taquetes, utilice la regla al pie de página 3.

MAXIMUM RECOMMENDED WEIGHT  
BEING THIS EVENLY DISTRIBUTED

PESO MÁXIMO RECOMENDADO SENDO  
ESTE DISTRIBUÍDO UNIFORMEMENTE

PESO MÁXIMO RECOMENDADO SIENDO  
ESTE UNIFORMEMENTE DISTRIBUIDO

|   |    |    |
|---|----|----|
| _ | LB | KG |
| D | 11 | 5  |
| H | 44 | 20 |

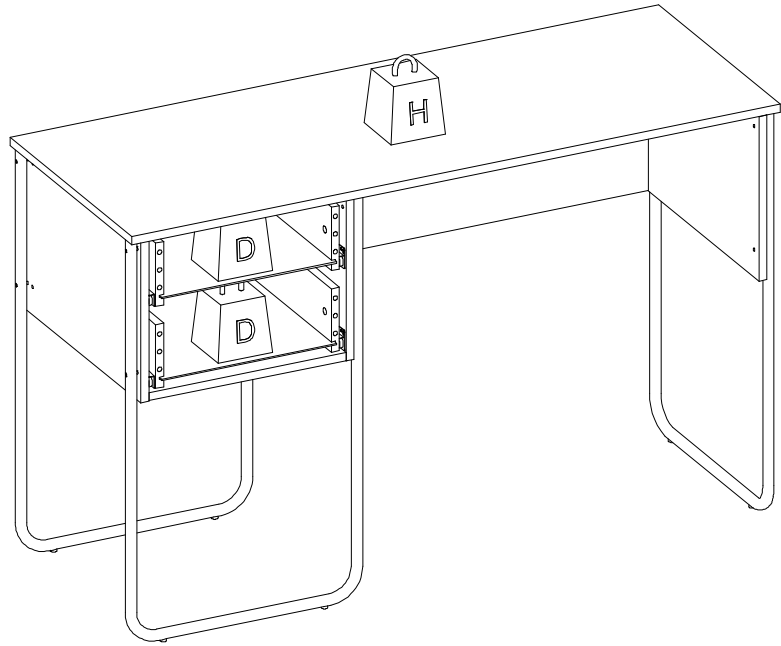





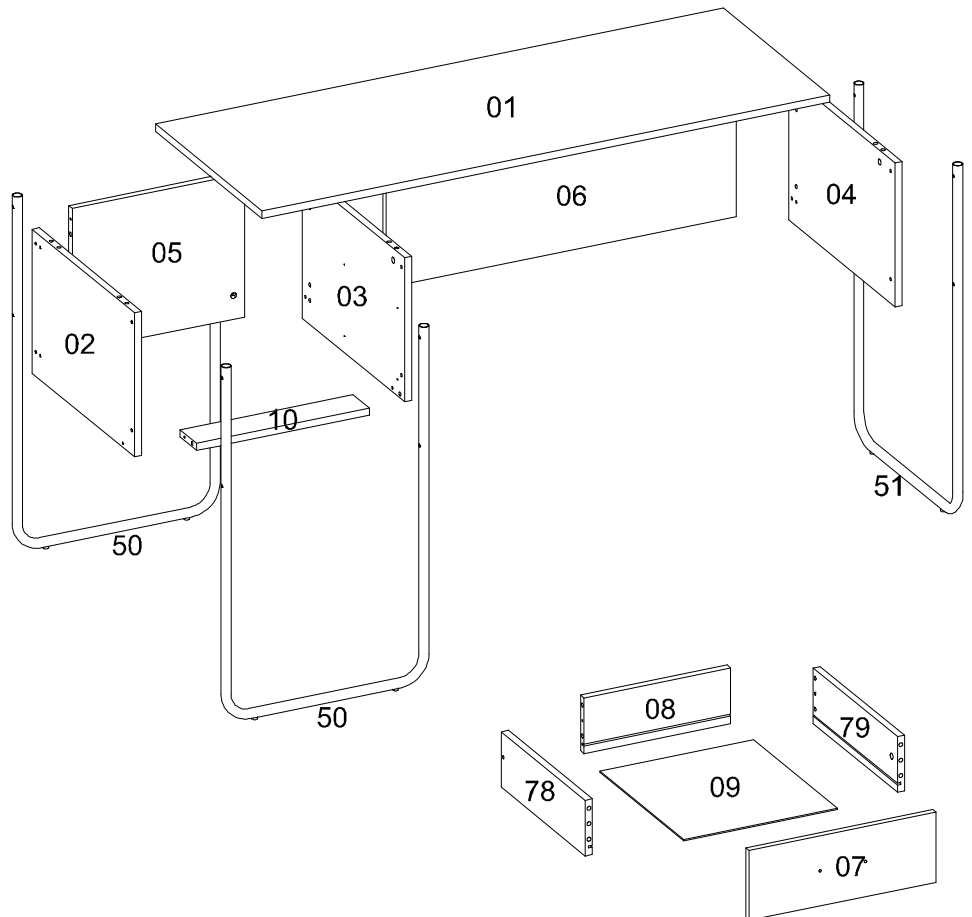





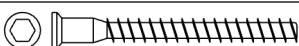

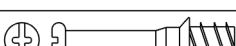
| Nº | Measures_Inches       | Medidas_cm         | Qty./Qtd. |
|----|-----------------------|--------------------|-----------|
| 01 | 47 1/4 x 17 3/4 x 5/8 | 120.0 x 45.0 x 1.5 | 1         |
| 02 | 11 3/4 x 17 x 5/8     | 29.8 x 43.3 x 1.5  | 1         |
| 03 | 11 3/4 x 17 x 5/8     | 29.8 x 43.3 x 1.5  | 1         |
| 04 | 11 3/4 x 17 3/4 x 5/8 | 29.8 x 45.0 x 1.5  | 1         |
| 05 | 14 3/8 x 11 3/4 x 5/8 | 36.5 x 29.7 x 1.5  | 1         |
| 06 | 29 1/8 x 11 3/4 x 5/8 | 74.0 x 29.7 x 1.5  | 1         |
| 07 | 15 1/2 x 5 3/4 x 5/8  | 39.5 x 14.5 x 1.5  | 2         |
| 08 | 12 1/4 x 4 1/2 x 5/8  | 31.0 x 11.5 x 1.5  | 2         |
| 09 | 12 3/4 x 13 7/8 x 1/8 | 32.4 x 35.4 x 0.3  | 2         |
| 10 | 14 3/8 x 2 3/4 x 5/8  | 36.5 x 7.0 x 1.5   | 1         |
| 78 | 14 x 4 1/2 x 5/8      | 35.5 x 11.5 x 1.5  | 2         |
| 79 | 14 x 4 1/2 x 5/8      | 35.5 x 11.5 x 1.5  | 2         |
| 50 | 29 1/4 x 17 1/4 x 3/4 | 74.2 x 43.7 x 1.9  | 2         |
| 51 | 29 1/4 x 17 1/4 x 3/4 | 74.2 x 43.7 x 1.9  | 1         |

**PARTS IDENTIFICATION**  
**IDENTIFICAÇÃO DAS PEÇAS / IDENTIFICACIÓN DE LAS PIEZAS**

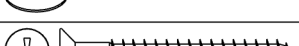
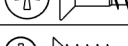
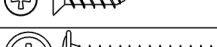

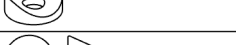
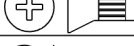
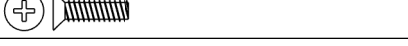
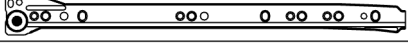
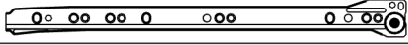
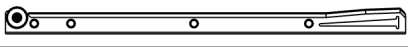
## IDENTIFICATION OF ACCESSORIES IDENTIFICAÇÃO DOS ACESSÓRIOS/ IDENTIFICACIÓN DE ACCESORIOS

|     |   |  |           |    |
|-----|---|--|-----------|----|
| A1  |    | Glue / Cola / Pegamento  | 13 g      | 1  |
| E   |    | Wooden dowel / Cavilha / Taquete   | 8x30 mm   | 28 |
| F   |    | Wooden dowel / Cavilha / Taquete   | 8x50 mm   | 2  |
| G   |    | Structural screw / Parafuso estrutural / Tornillo estructural                            | 5,0x50 mm | 6  |
| H   |    | Allen key / Chave allen / Liave allen  | 3 mm      | 1  |
| I   |    | Structural screw cover/Tampa parafuso estrutural/Tapa tornillo estructural               | -         | 6  |
| J   |    | Simple minifix screw / Haste minifix simples / Tornillo minifix simple                   | -         | 10 |
| K   |    | Double minifix screw / Haste minifix dupla / Tornillo minifix doble                      | 60mm      | 2  |
| L   |    | Drum lock / Tambor minifix / Tambor minifix  | 12 mm     | 14 |
| M   |    | Bore patch adhesive / Tapa furo adesivo / Tapones adhesivo                               | -         | 8  |
| O   |    | Flat head screw / Parafuso chato / Tornillo de cabeza plana                              | 4,5x45 mm | 4  |
| P5  |    | Flat head screw / Parafuso chato especial / Tornillo de cabeza plana                     | 3,5x14 mm | 16 |
| T   |    | Flanged head screw / Parafuso flangeado / Tornillo de cabeza flangeada                   | 3,5x25 mm | 4  |
| U11 |    | Concave ring / Arruela côncava / Anillo cóncavo  | 3/16      | 12 |
| U12 |    | Union flat head screw / Parafuso união chato / Tornillo unión plano                      | 27 mm     | 12 |
| U13 |    | Union flat head screw / Parafuso união chato / Tornillo unión plano                      | 4,0x16 mm | 12 |
| VA  |  | Metallic slide the left field / Corrediça lateral esquerda / Corredera lateral izquierda | 350 mm    | 2  |
| VB  |  | Metallic slide the right field / Corrediça lateral direita / Corredera lateral derecha   | 350 mm    | 2  |
| VC  |  | Drawer slide left / Corrediça gaveta esquerda / Corredera izquierda cajón                | 350 mm    | 2  |
| VD  |  | Drawer slide right / Corrediça gaveta direita / Corredera derecha cajón                  | 350 mm    | 2  |
| W7  |  | Handle / Puxador Goleira / Tirador   | 96 mm     | 2  |

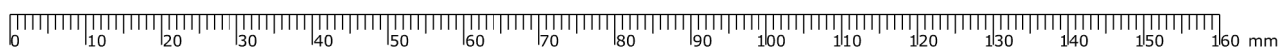

PRE-ASSEMBLE  
PRÉ-MONTAGEM / PRE ARMADO

01

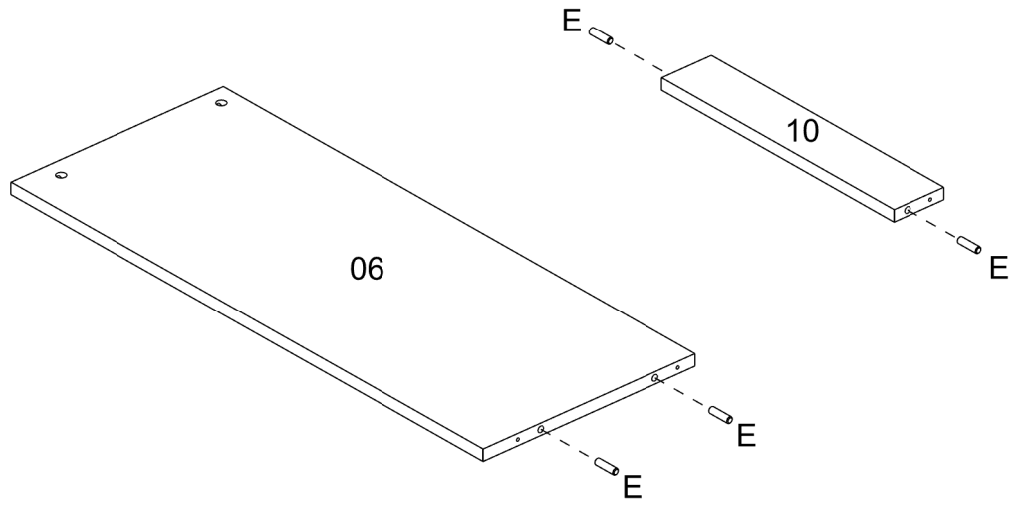
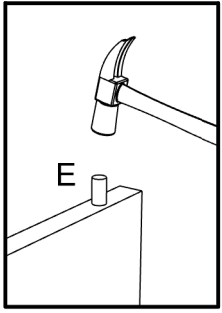

02

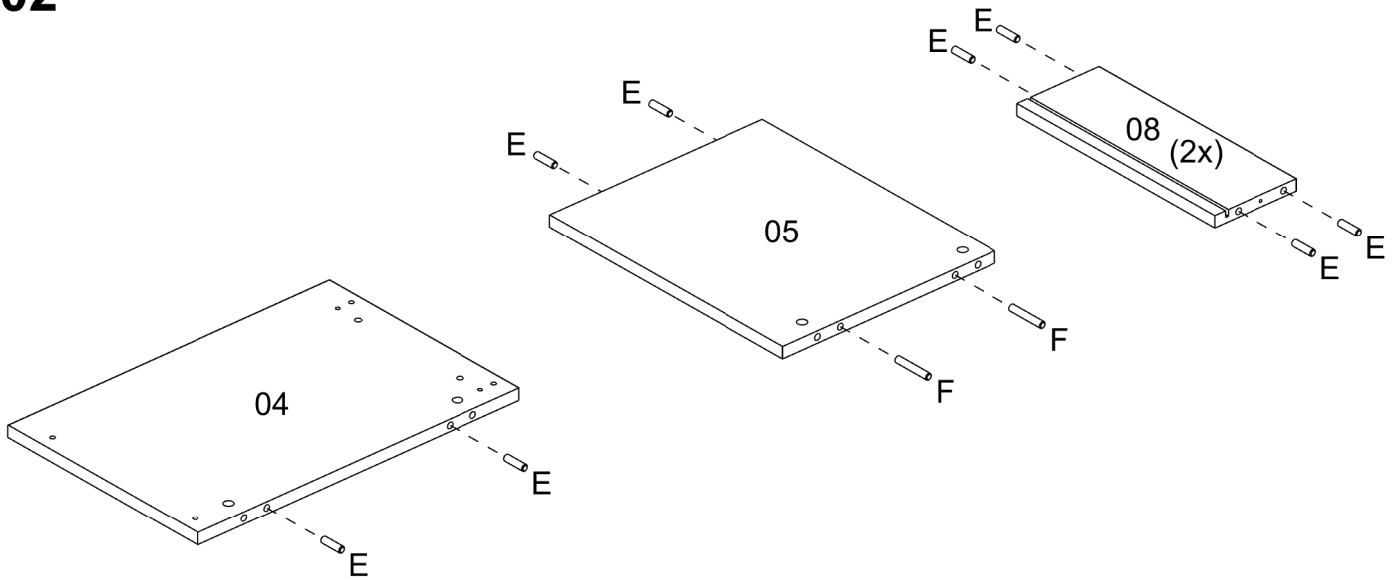

03

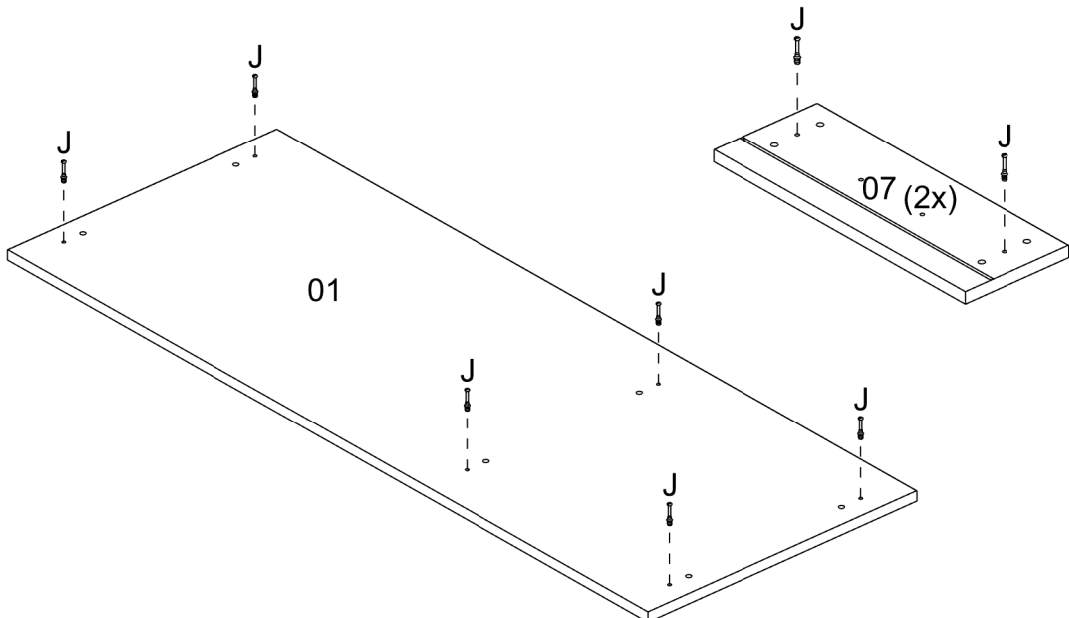
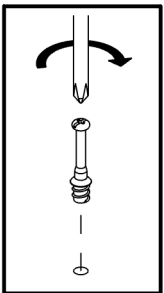

04

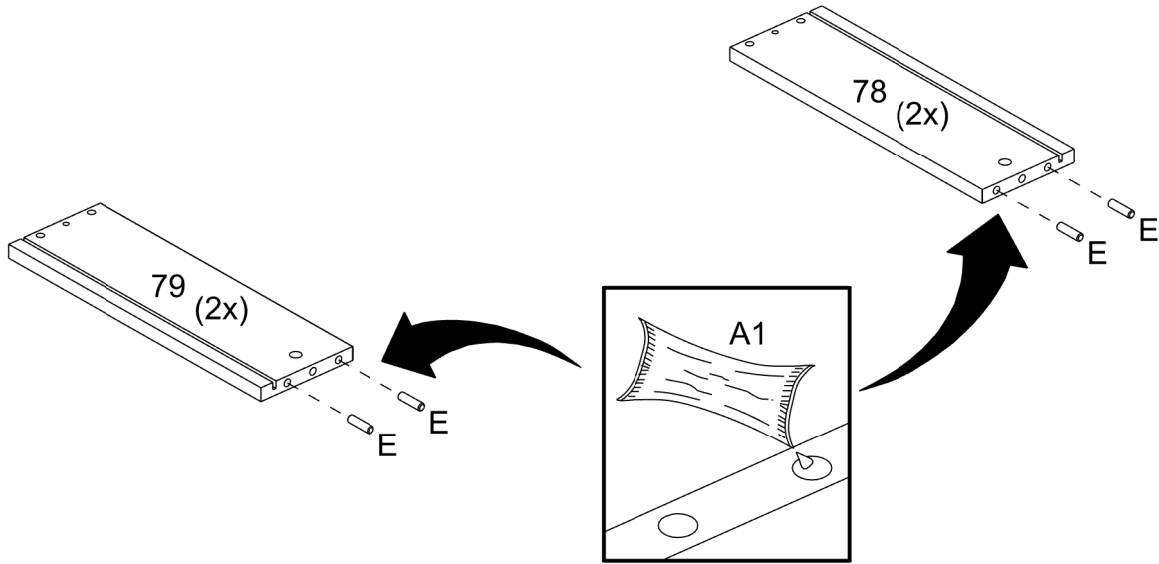

05

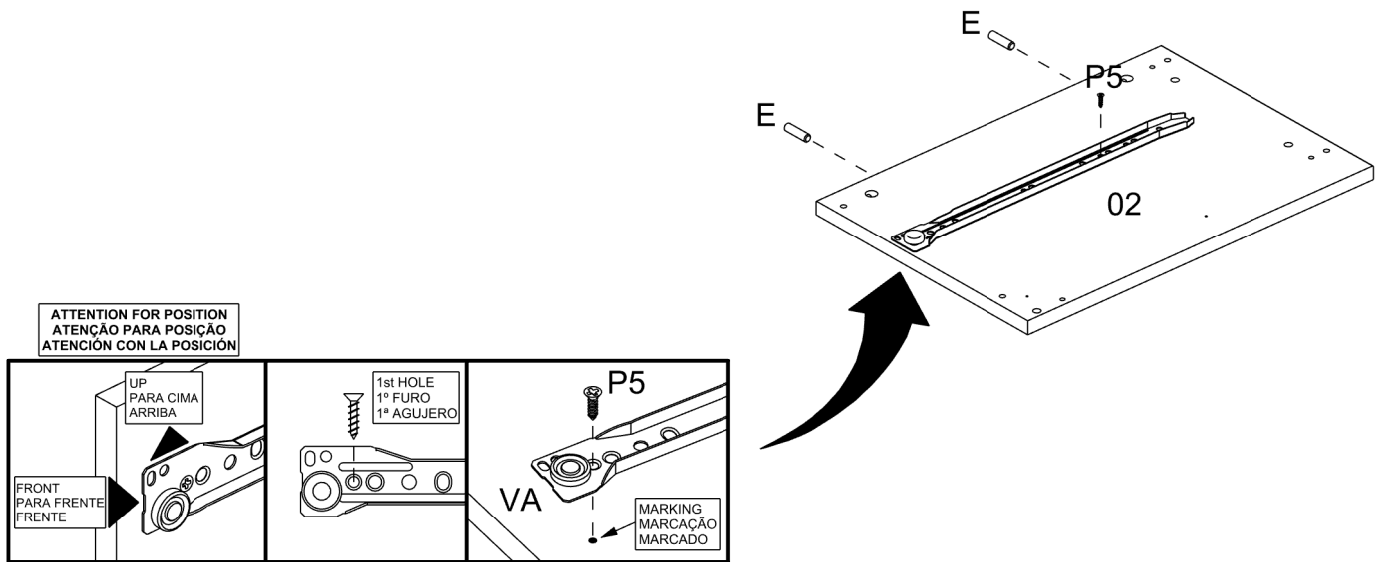

06

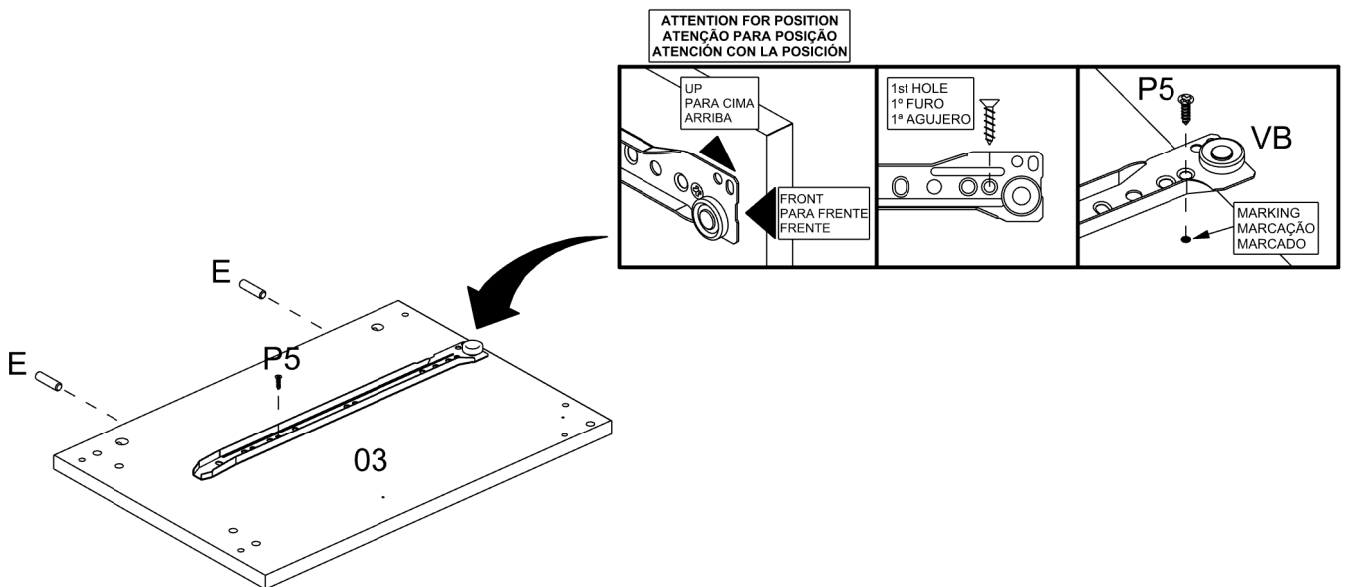

ASSEMBLY  
MONTAGEM / ARMADO

07

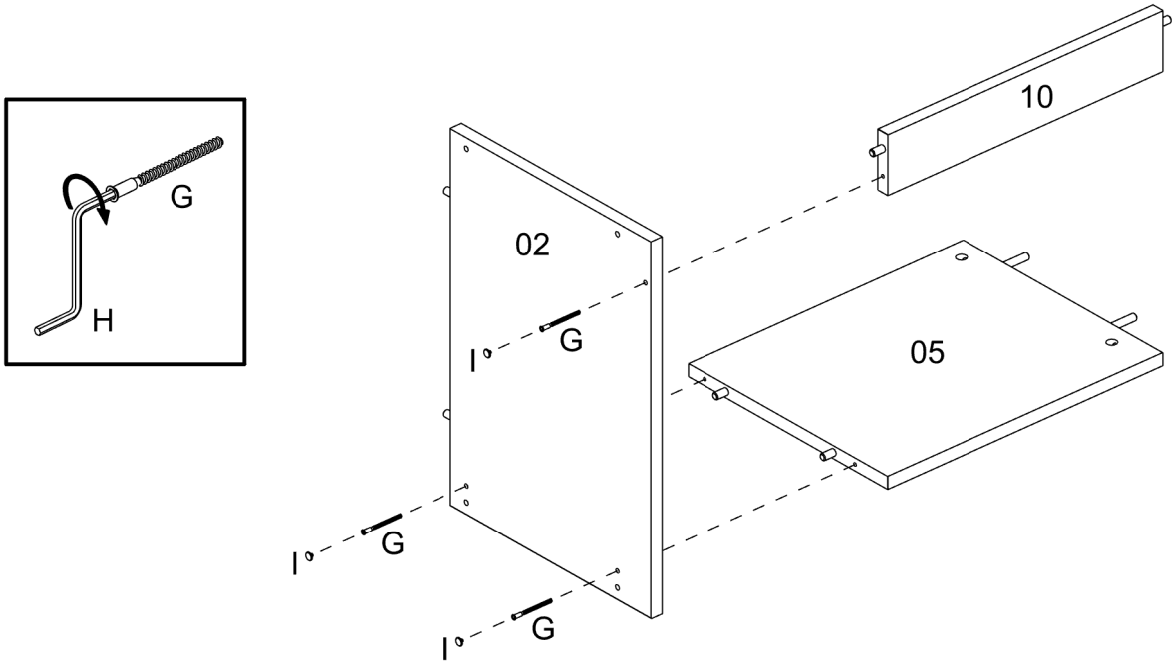

08

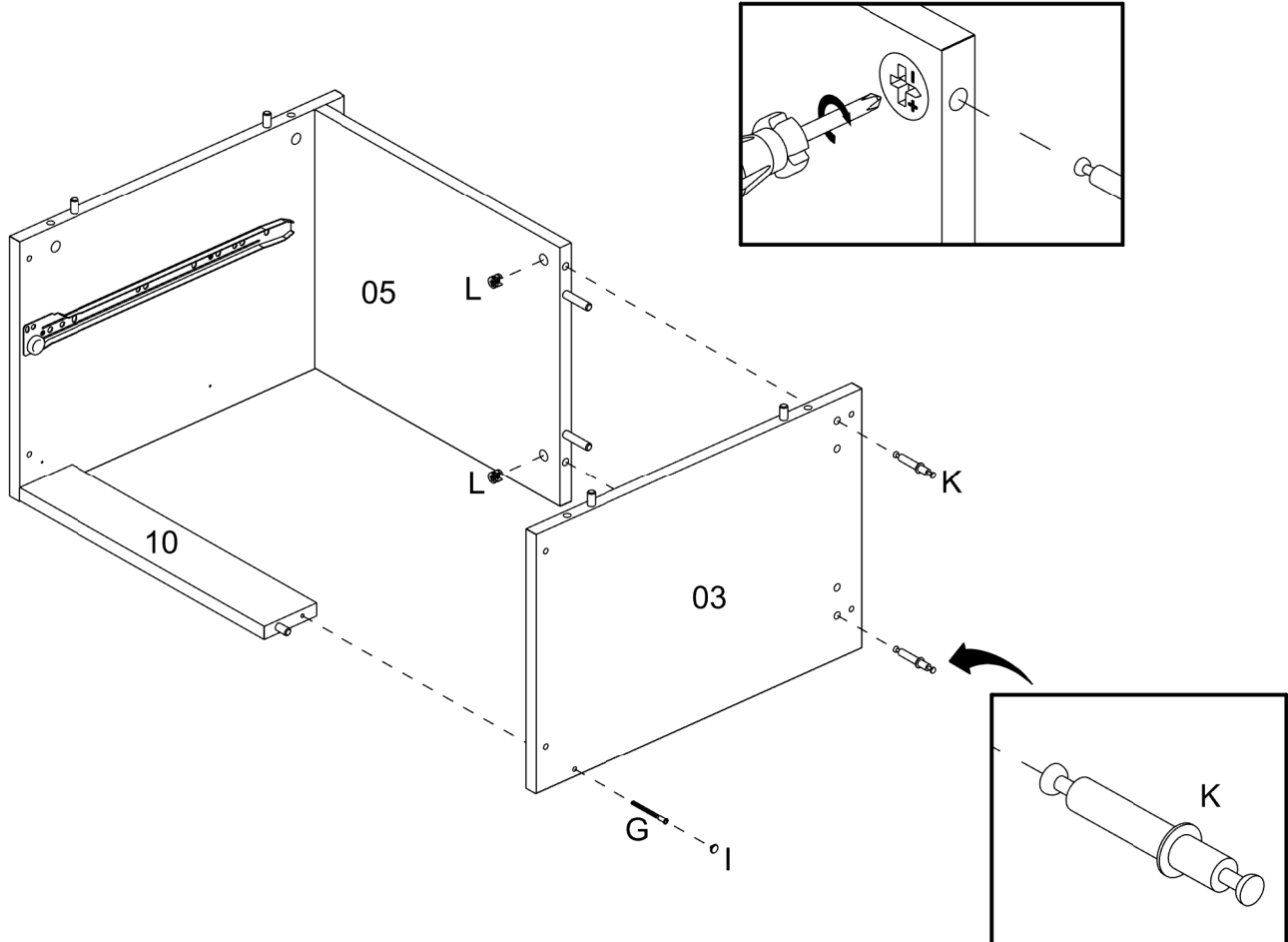

09

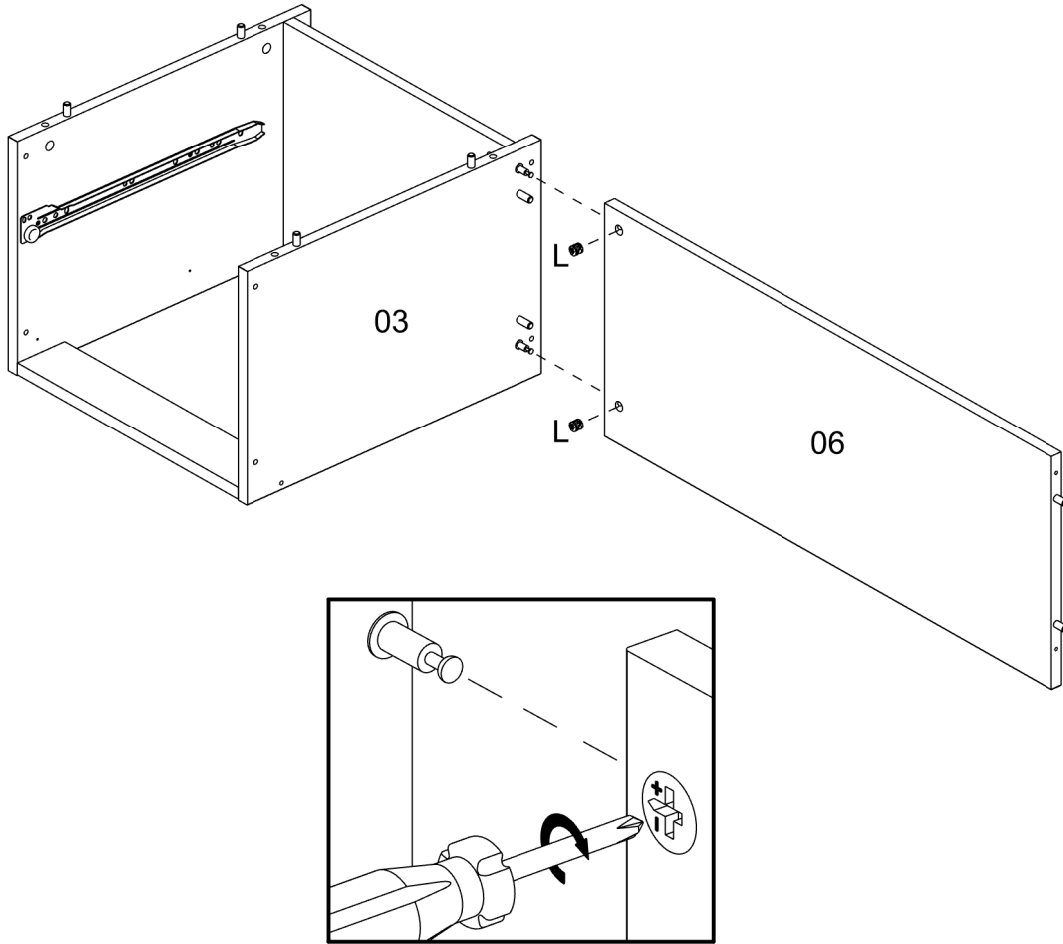

10

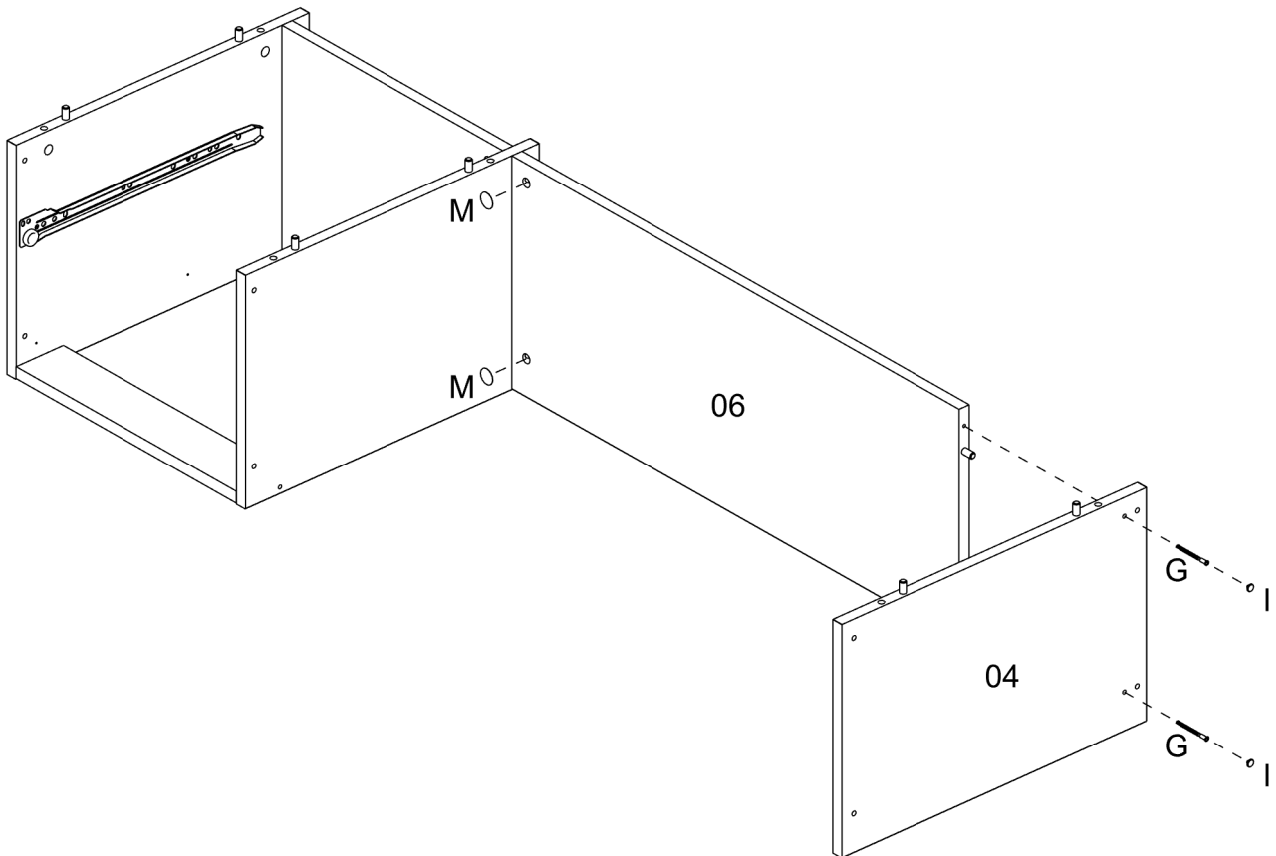

11

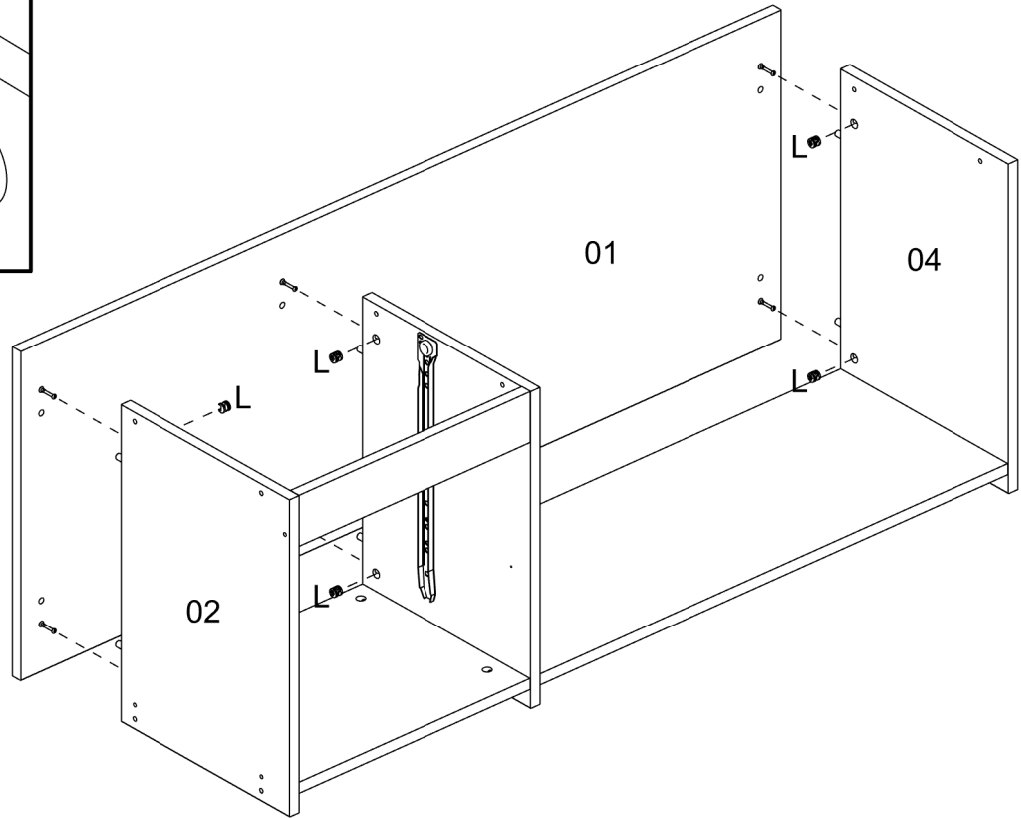
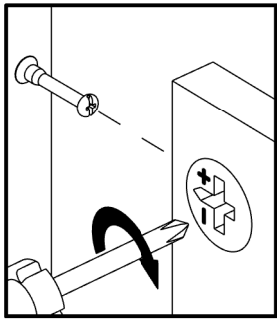

12

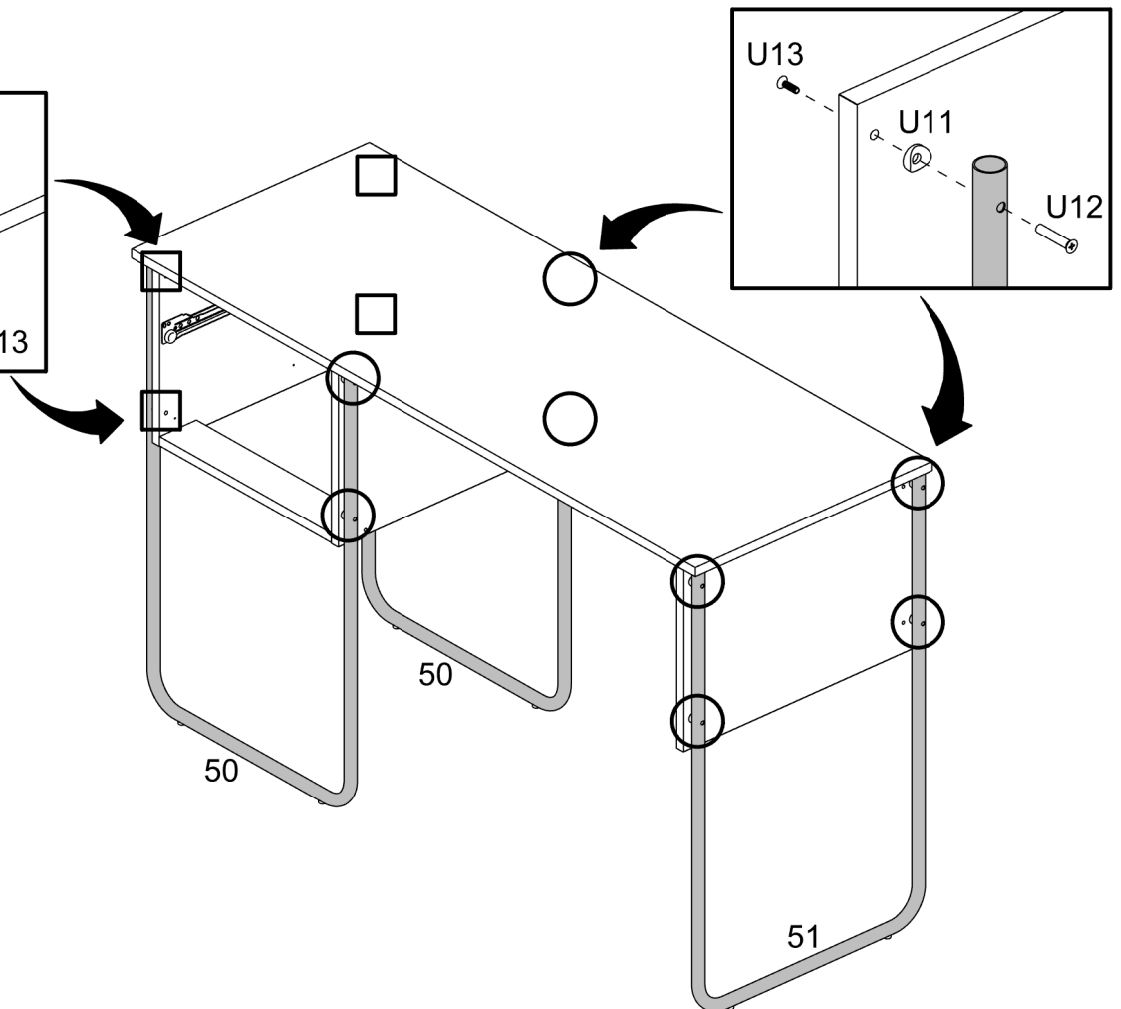
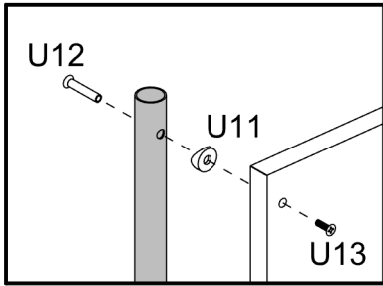



# 13

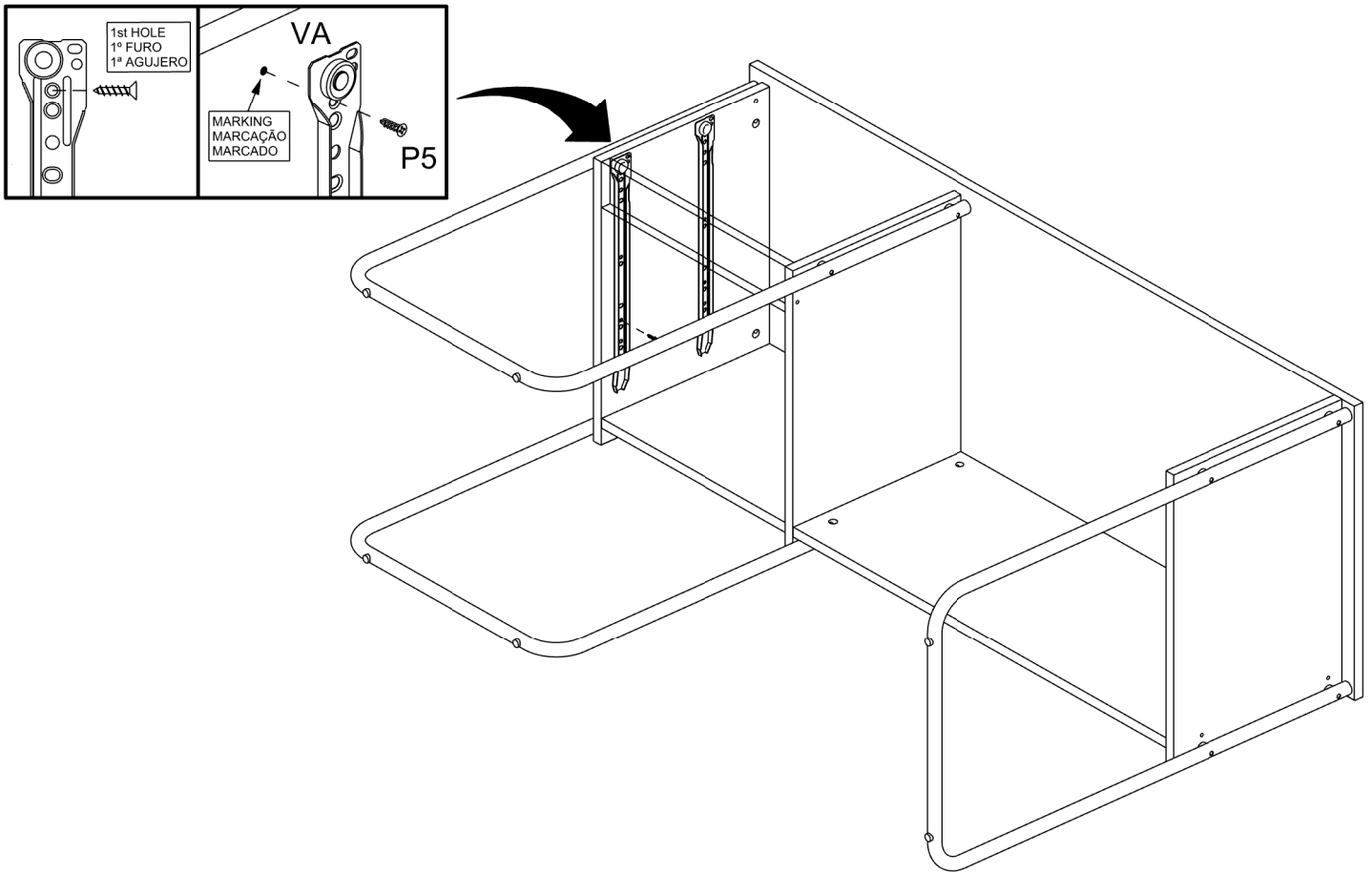

# 14

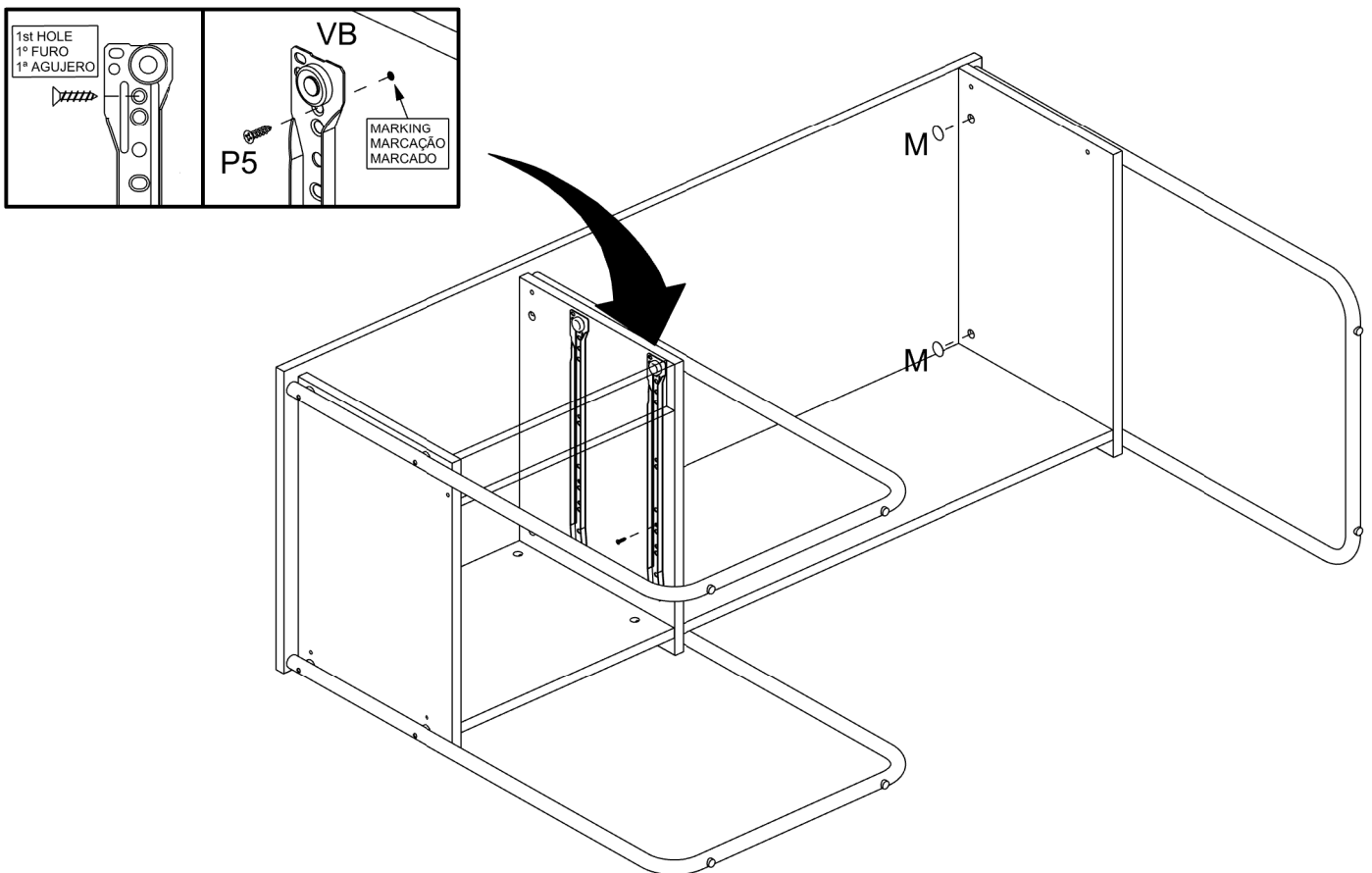

15

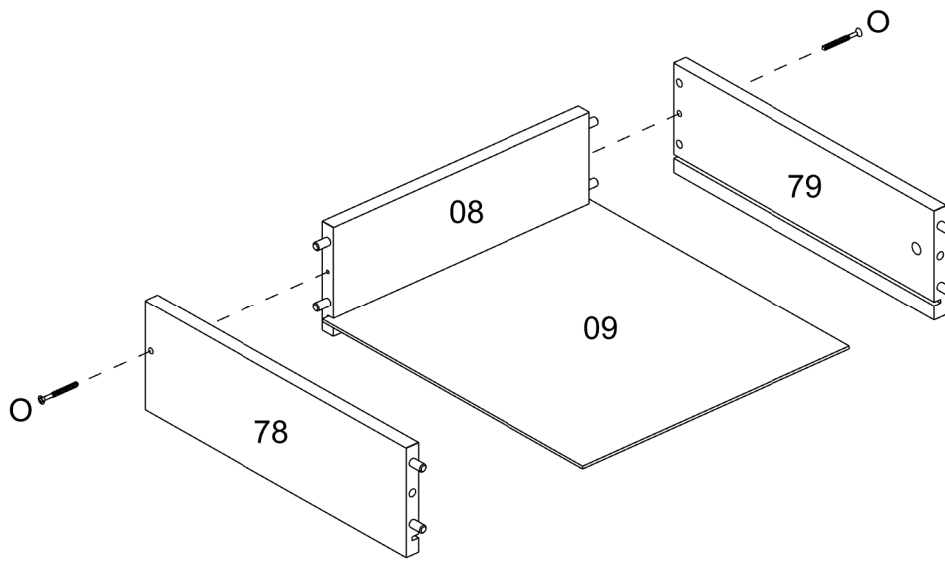

16

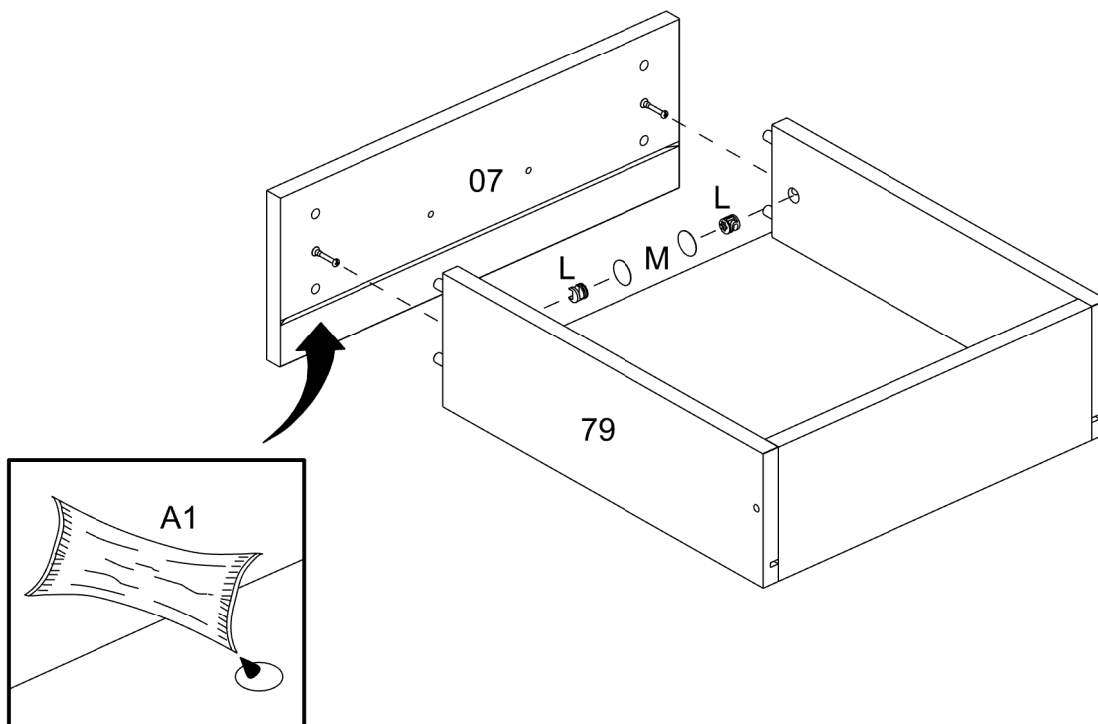

17

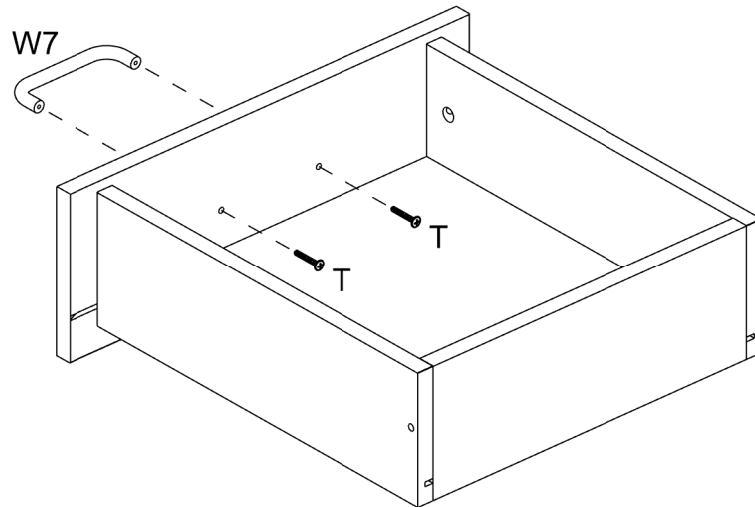

18

THE UNDERSIDE OF THE DRAWER  
LADO INFERIOR DA GAVETA  
PARTE INFERIOR DEL CAJÓN

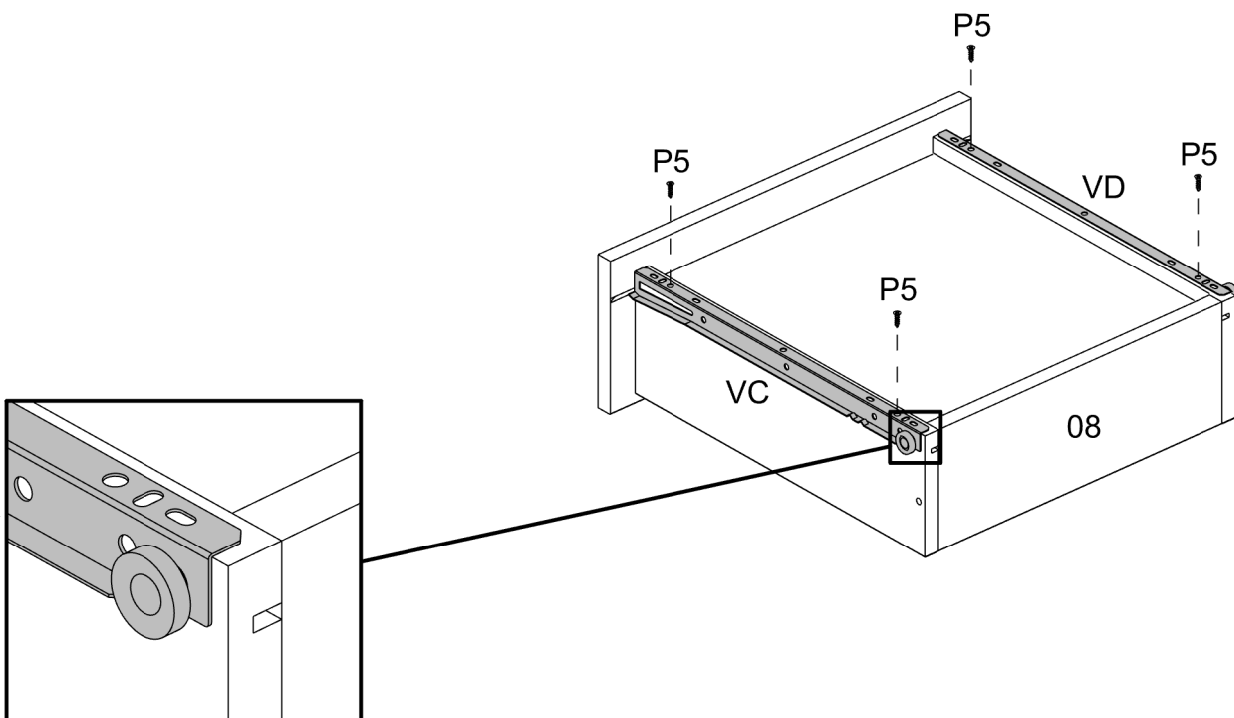

19

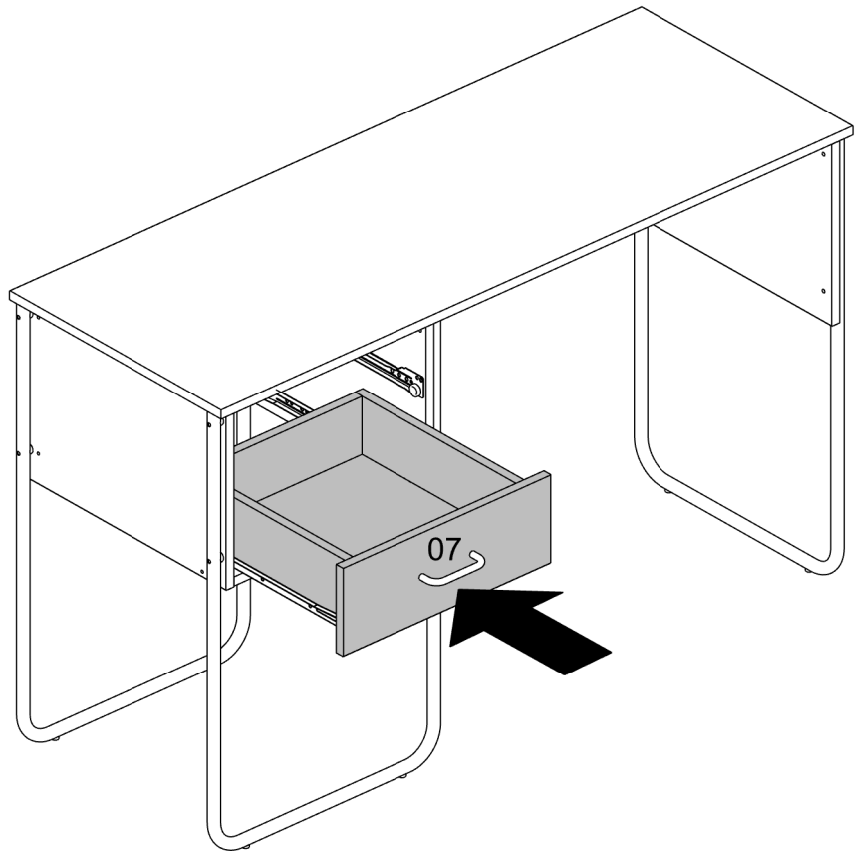
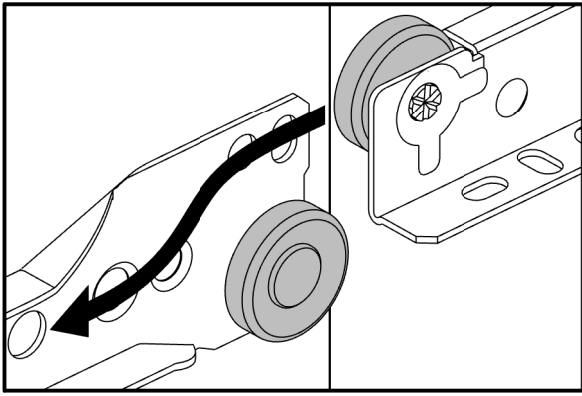

20

