

ASSEMBLY INSTRUCTIONS MANUAL DE MONTAGEM / INSTRUCCIONES DE ARMADO

ITAIM BASE CABINET - 1 DRAWER 2 DOORS

BALCÃO ITAIM - 1 GAVETA 2 PORTAS

GABINETE ITAIM - 1 CAJÓN 2 PUERTAS

Reference
Referência
Referencia

210278

Revise
Revisão
Revisión

00

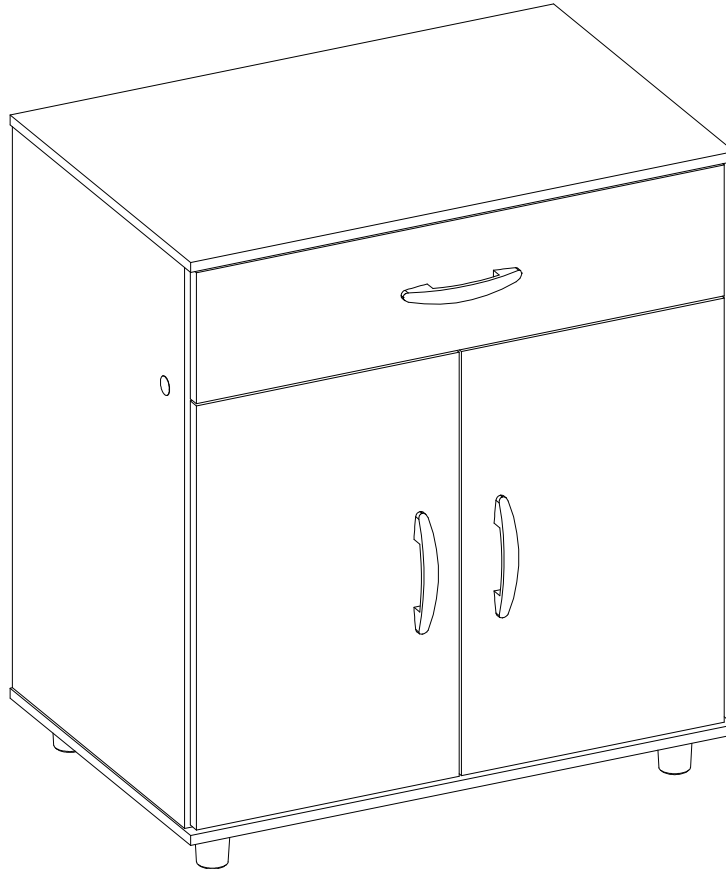

YOU WILL NEED / VOCÊ VAI PRECISAR DE / USTED NECESITARÁ

Tools not supplied / Ferramentas não fornecidas / Herramientas no incluidas

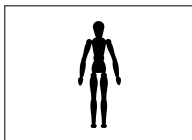

1 Person
1 Pessoa
1 Persona

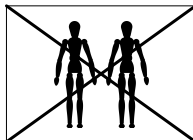

2 People
2 Pessoas
2 Personas

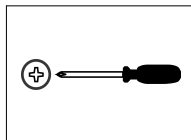

Screwdriver Phillips
Chave Phillips
Destornillador cruz

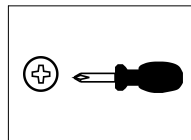

Small screwdriver Philips
Chave Phillips menor
Destornillador cruz menor

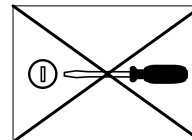

Screwdriver slotted
Chave fenda
Destornillador plano

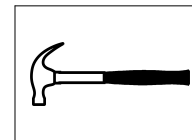

Hammer
Martelo
Martillo

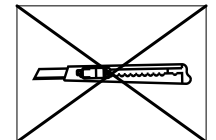

Stylet
Estilete
Estilete

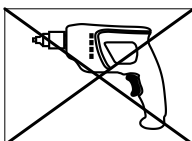

Drill machine
Furadeira
Taladro

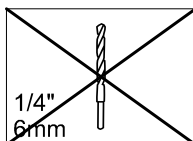

Drill bit
Broca
Taladro

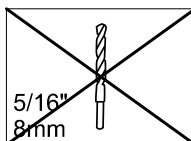

Drill bit
Broca
Taladro

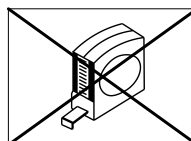

Measuring tape
Trena
Cinta de medición

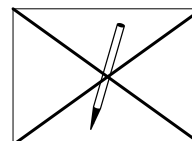

Pencil
Lápis
Lápiz

NOTES: The separation of the accessories before you start the assembly will facilitate the same. In case of doubt on the size of the screws and bolts, use the ruler to bottom of page 3.

NOTAS: A separação dos acessórios antes de iniciar a montagem facilitará a mesma. Em caso de dúvida no tamanho dos parafusos e cavilhas, utilize a régua ao final da página 3.

NOTAS: La separación de los accesorios antes de comenzar el armado facilitará el mismo. En caso de duda sobre el tamaño de los tornillos y taquetes, utilice la regla al pie de página 3.

MAXIMUM RECOMMENDED WEIGHT
BEING THIS EVENLY DISTRIBUTED

PESO MÁXIMO RECOMENDADO SENDO
ESTE DISTRIBUÍDO UNIFORMEMENTE

PESO MÁXIMO RECOMENDADO SIENDO
ESTE UNIFORMEMENTE DISTRIBUIDO

_	LB	KG
D	11	5
F	22	10

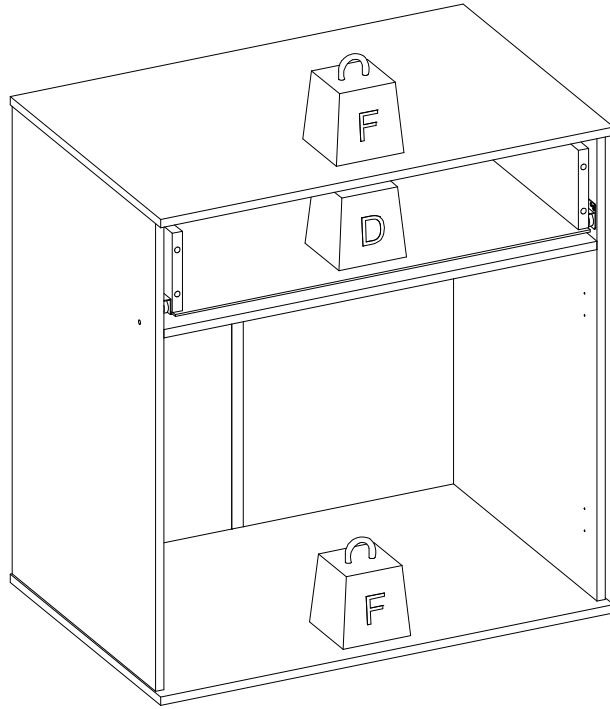





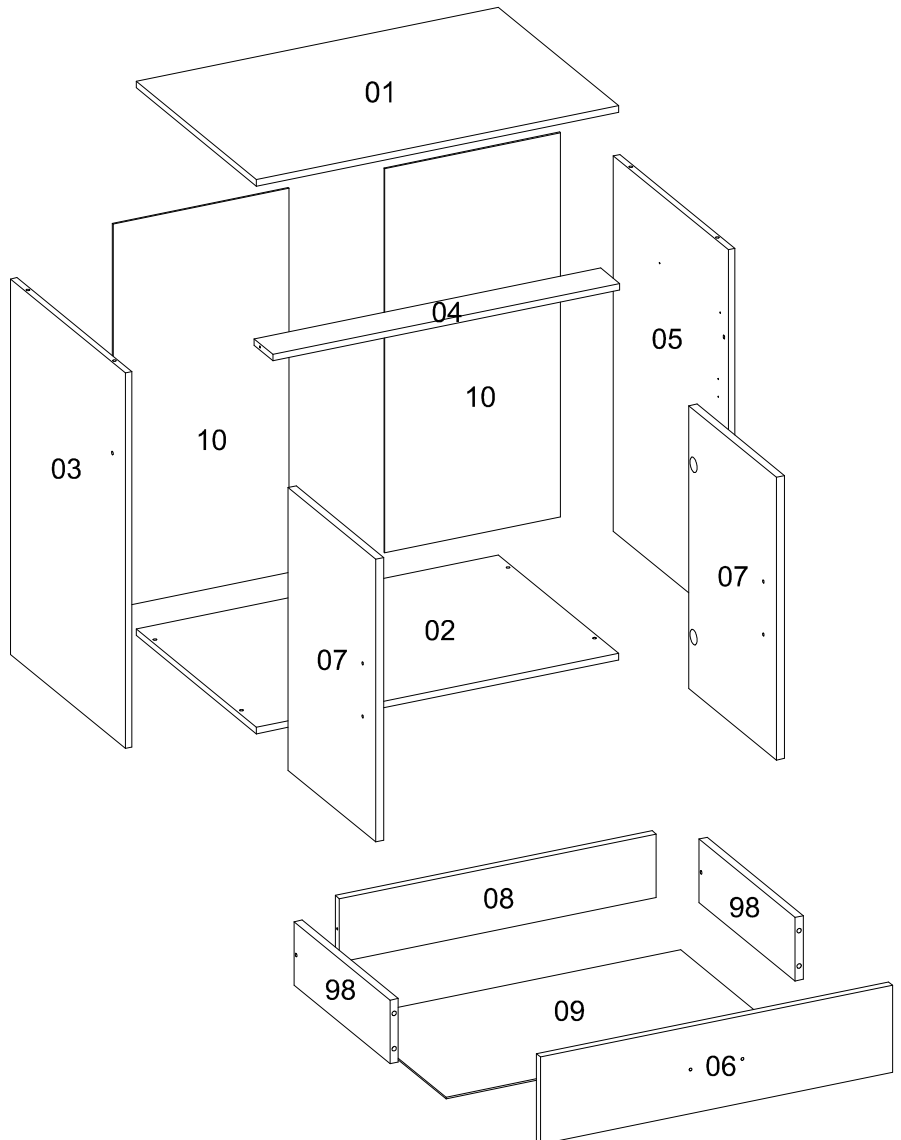



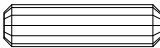

N°	Measures_Inches	Medidas_cm	Qty./Qtd.
01	26 3/8 x 17 1/2 x 1/2	67.0 x 44.5 x 1.2	1
02	26 3/8 x 17 1/2 x 1/2	67.0 x 44.5 x 1.2	1
03	26 3/4 x 16 3/4 x 1/2	68.0 x 42.5 x 1.2	1
04	25 1/4 x 2 3/4 x 1/2	64.1 x 7.0 x 1.2	1
05	26 3/4 x 16 3/4 x 1/2	68.0 x 42.5 x 1.2	1
06	25 5/8 x 6 1/4 x 5/8	65.1 x 15.8 x 1.5	1
07	20 1/8 x 12 3/4 x 5/8	51.2 x 32.4 x 1.5	2
08	23 1/8 x 4 1/2 x 5/8	58.6 x 11.5 x 1.5	1
09	24 1/8 x 14 1/4 x 1/8	61.4 x 36.1 x 0.3	1
10	27 3/8 x 12 3/4 x 1/8	69.6 x 32.5 x 0.3	2
98	14 x 4 1/2 x 5/8	35.5 x 11.5 x 1.5	2

PARTS IDENTIFICATION
IDENTIFICAÇÃO DAS PEÇAS / IDENTIFICACIÓN DE LAS PIEZAS

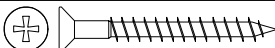

IDENTIFICATION OF ACCESSORIES IDENTIFICAÇÃO DOS ACESSÓRIOS/ IDENTIFICACIÓN DE ACCESORIOS

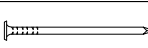
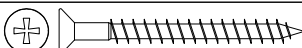
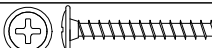
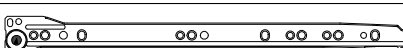
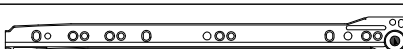
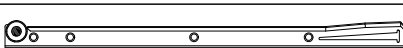
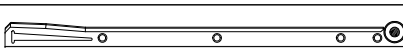
A1		Glue / Cola / Pegamento	13 g	1
A6		"H" profile / Perfil "H" / Perfil "H"	-	1
A4		Metalic bracket / Cantoneira de metal / Suporte de metal	22x22 mm	6
C2		Handle / Puxador Partenon / Tirador	96 mm	3
D5		Hinge shim / Calço dobradiça / Bisagra de calce	-	4
E		Wooden dowel / Cavilha / Taquete	8x30 mm	4
E8		Plastic foot / Pé de rack / Pie plástico	50 mm	4
F1		Wooden dowel / Cavilha / Taquete	6x30 mm	4
F6		Metal hinge curve / Dobradiça curva / Esquina de bisagra metálica	26 mm	4
K6		Flat head screw / Parafuso chato / Tornillo de cabeza plana	4,5x40 mm	4
L9		Flat head screw / Parafuso chato / Tornillo de cabeza plana	3,5x12 mm	36
M		Bore patch adhesive / Tapa furo adesivo / Tapones adhesivo	-	2
N		Nail / Pregó / Clavo	10x10	42
O		Flat head screw / Parafuso chato / Tornillo de cabeza plana	4,5x45 mm	8
T		Flanged head screw / Parafuso flangeado / Tornillo de cabeza flangeada	3,5x25 mm	6
VA		Metallic slide the left field / Corrediça lateral esquerda / Corredera lateral izquierda	350 mm	1
VB		Metallic slide the right field / Corrediça lateral direita / Corredera lateral derecha	350 mm	1
VC		Drawer slide left / Corrediça gaveta esquerda / Corredera izquierda cajón	350 mm	1
VD		Drawer slide right / Corrediça gaveta direita / Corredera derecha cajón	350 mm	1

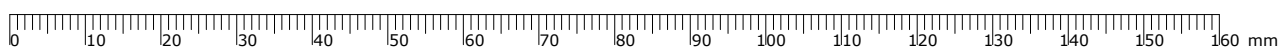

PRE-ASSEMBLE
PRÉ-MONTAGEM / PRE ARMADO

01

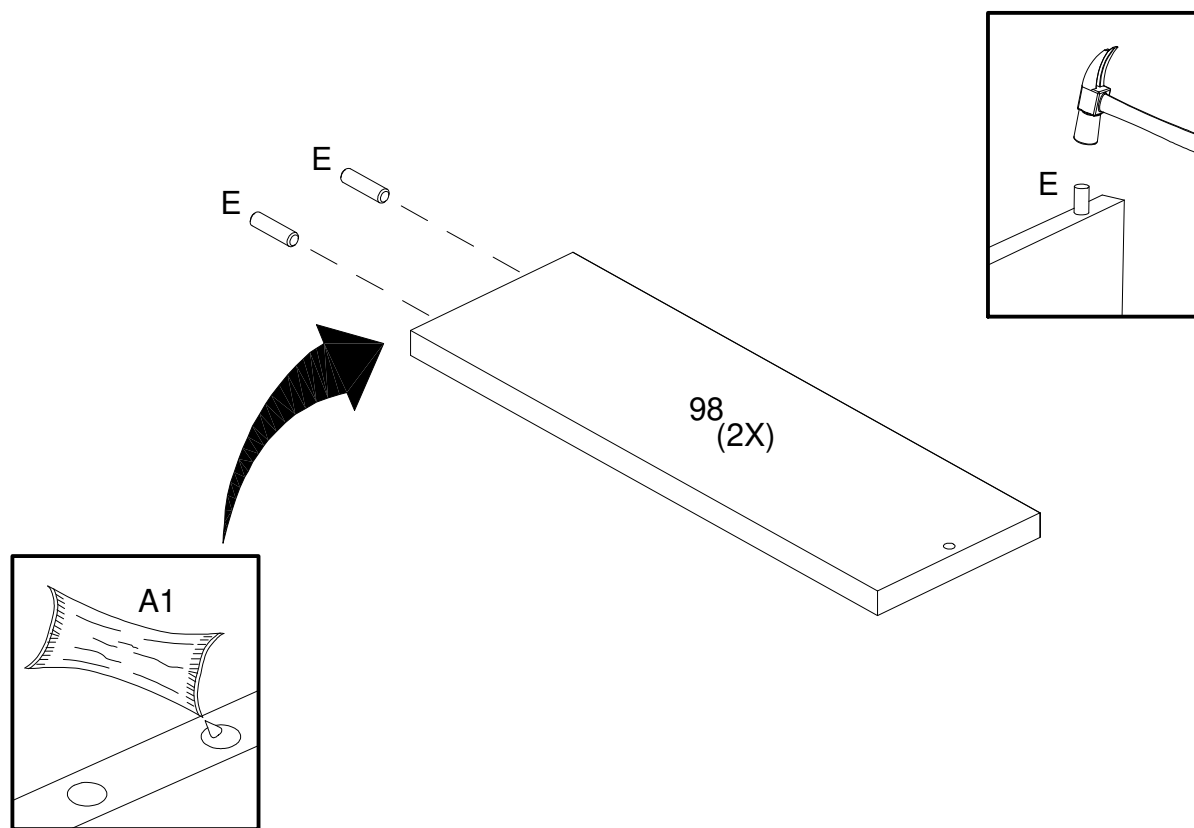

02

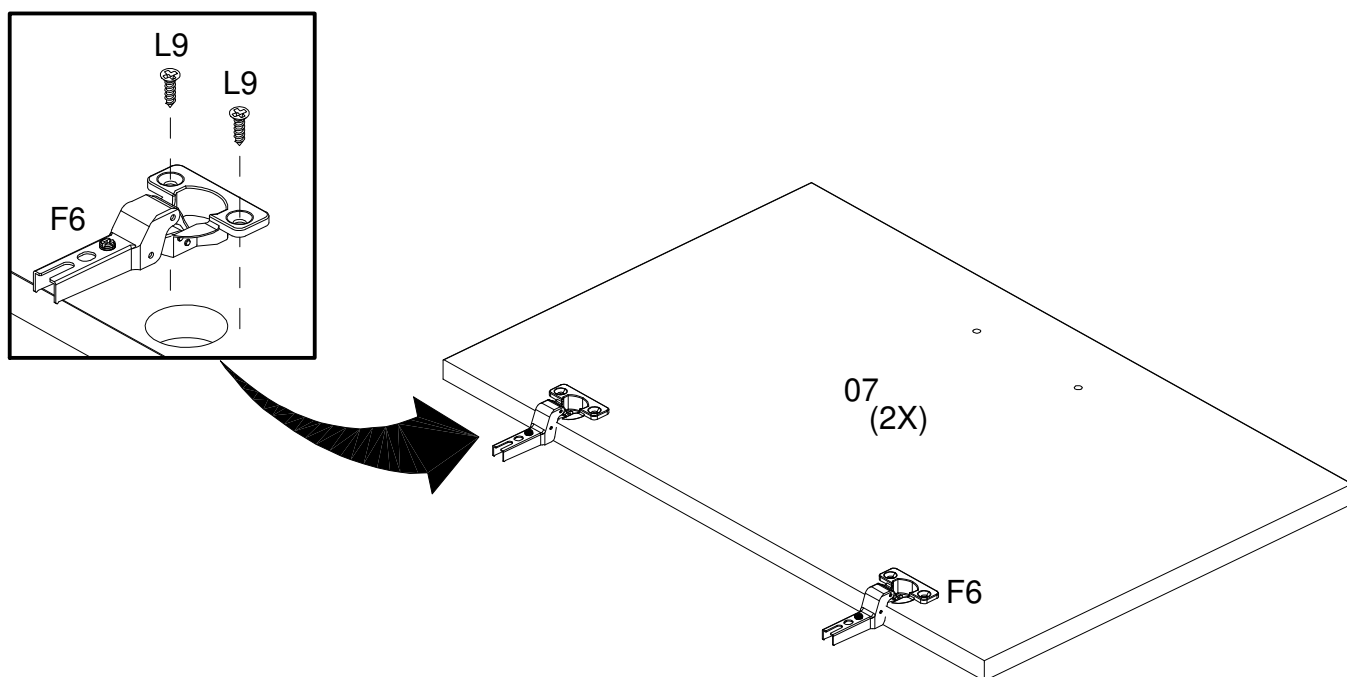

03

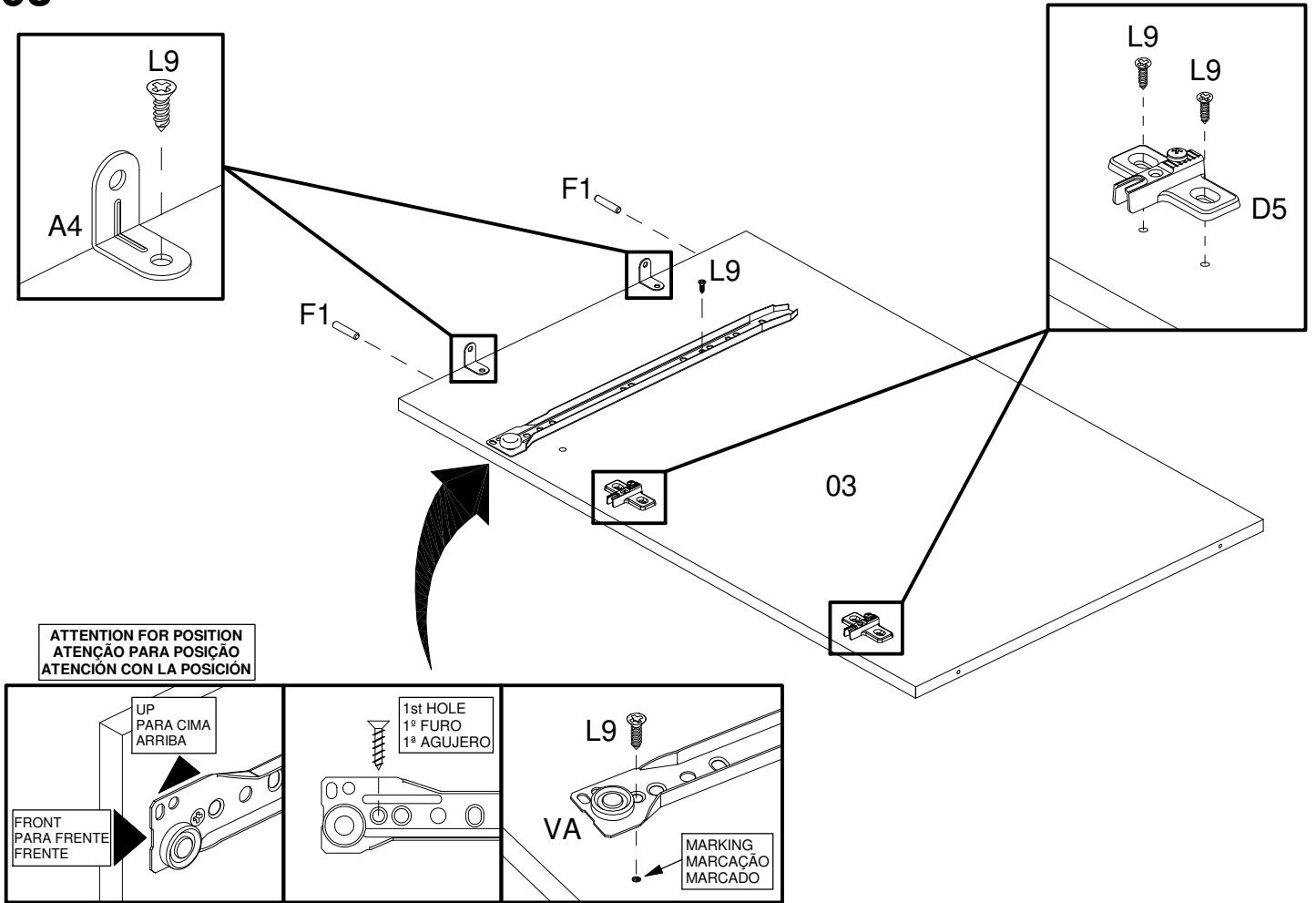

04

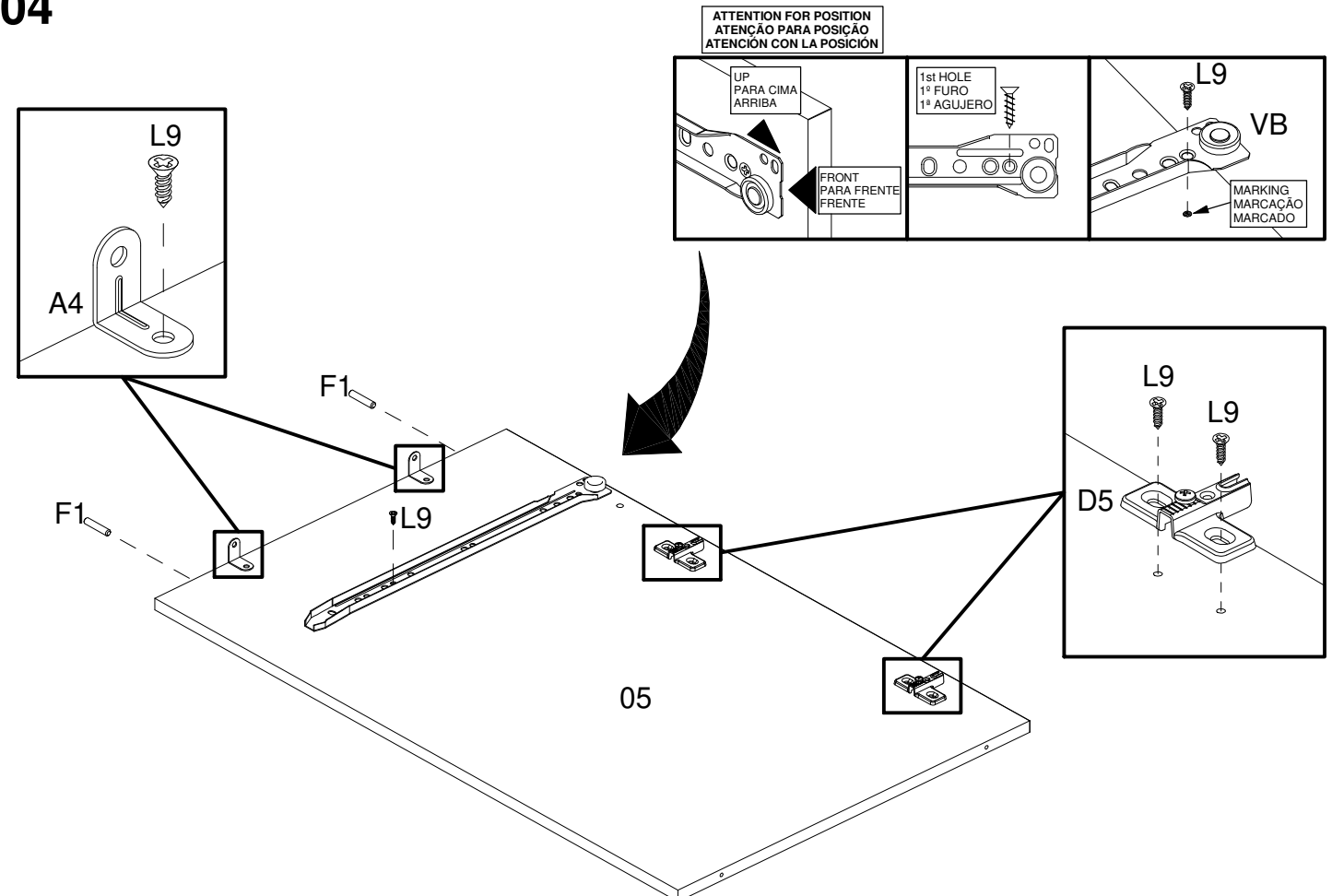

ASSEMBLY
MONTAGEM / ARMADO

05

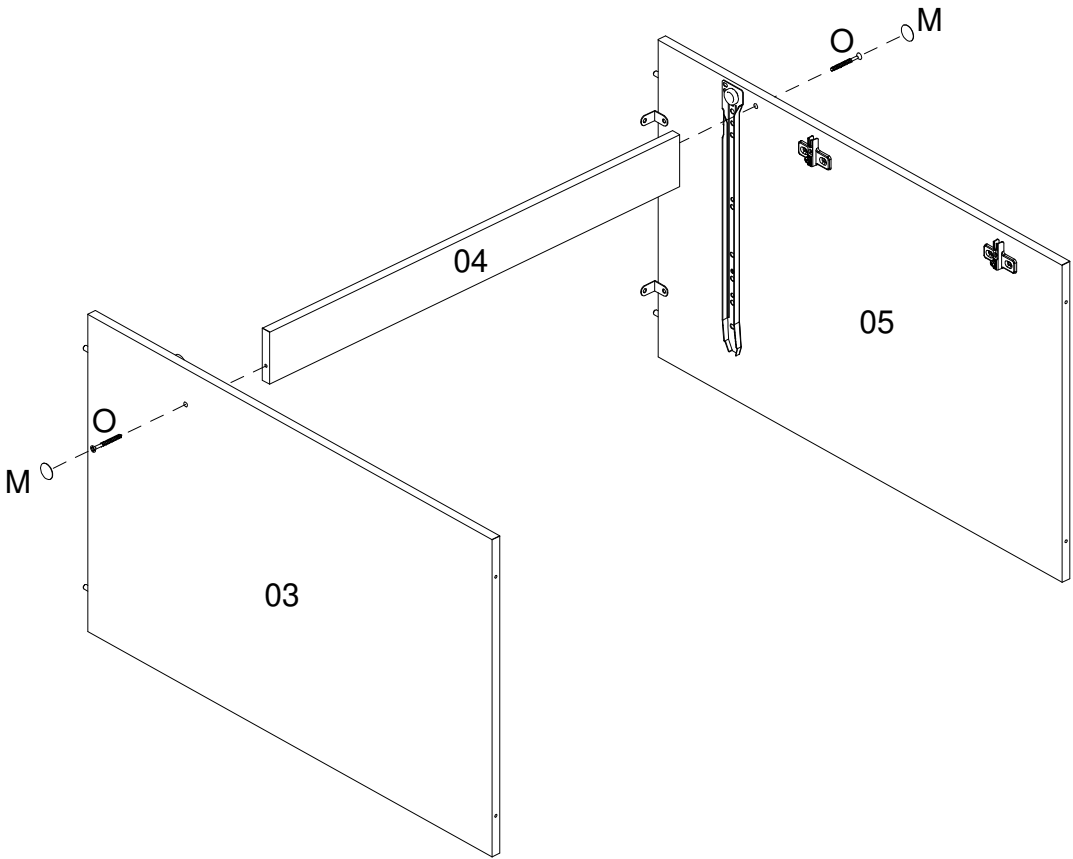

06

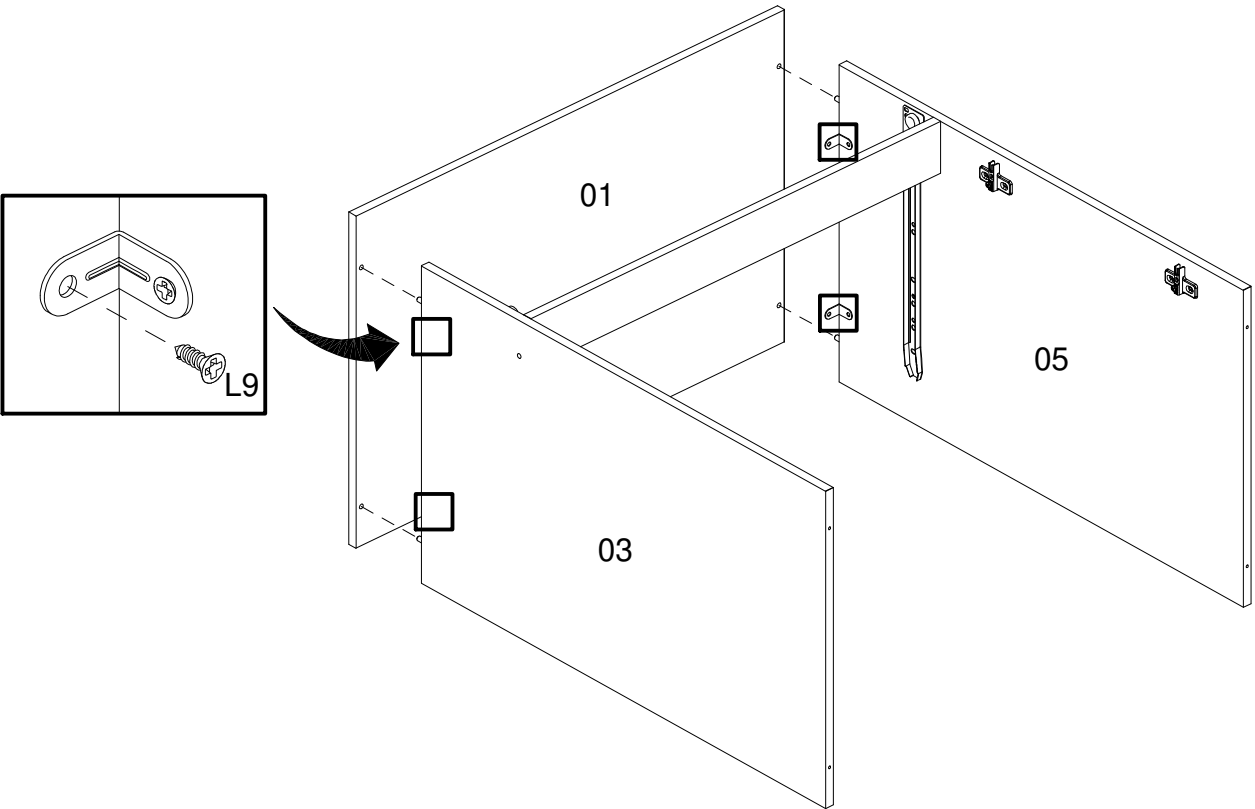

07

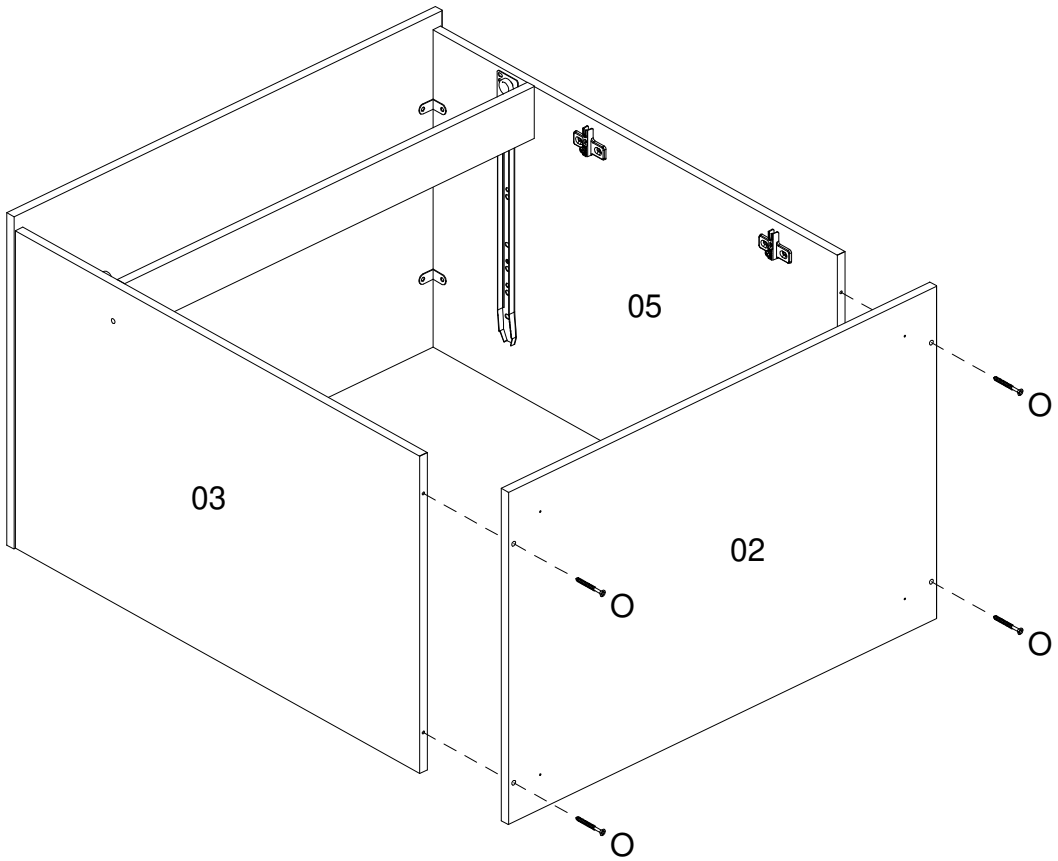

08

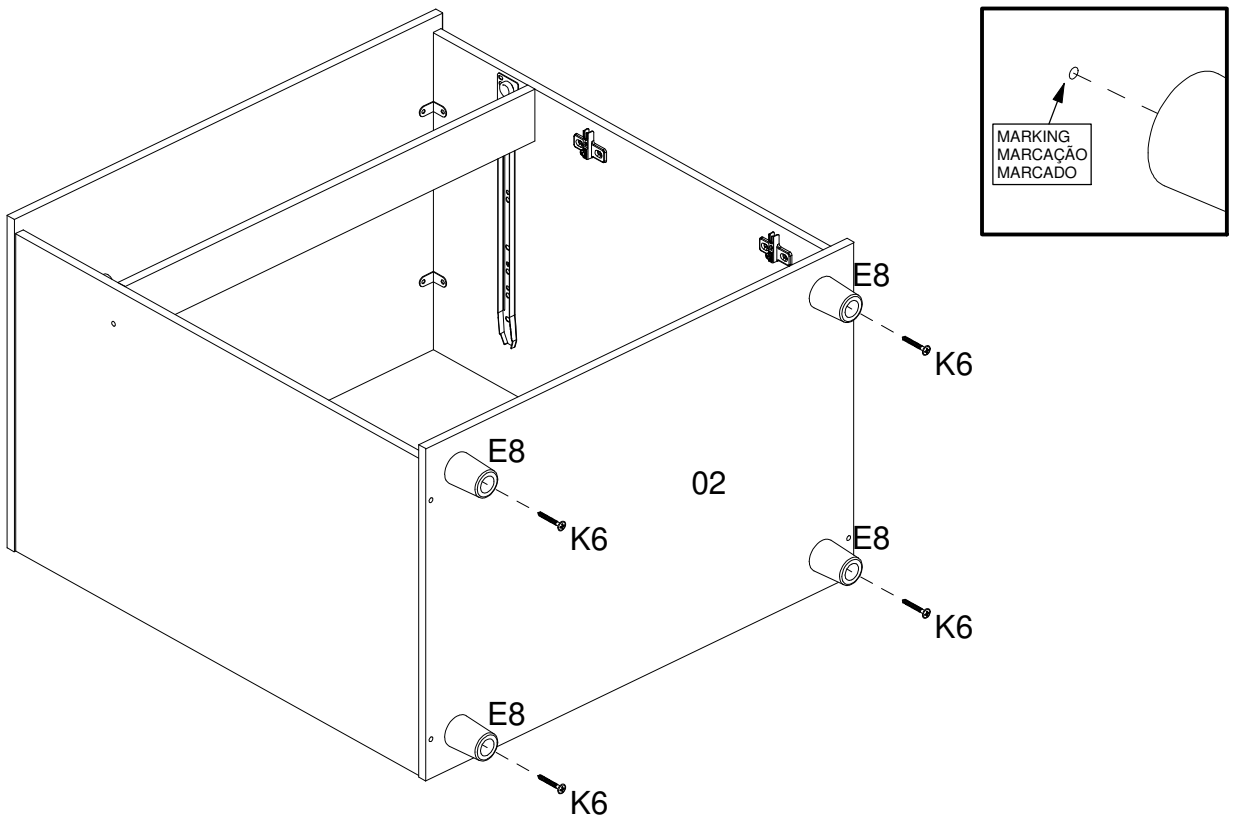

09

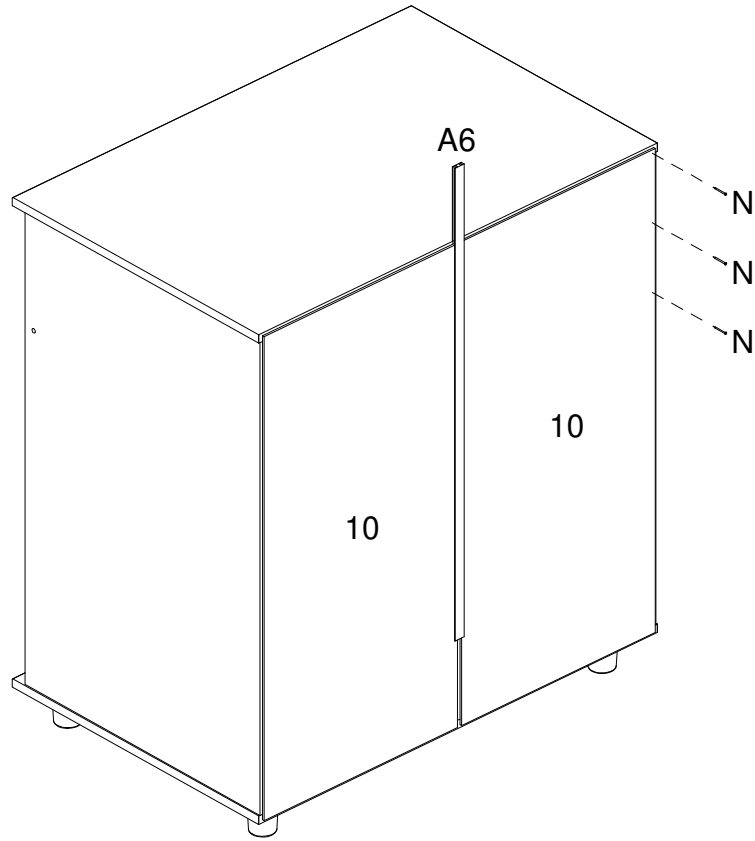

10

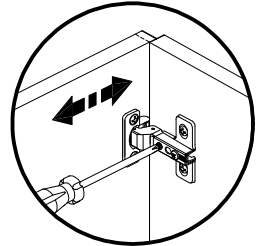
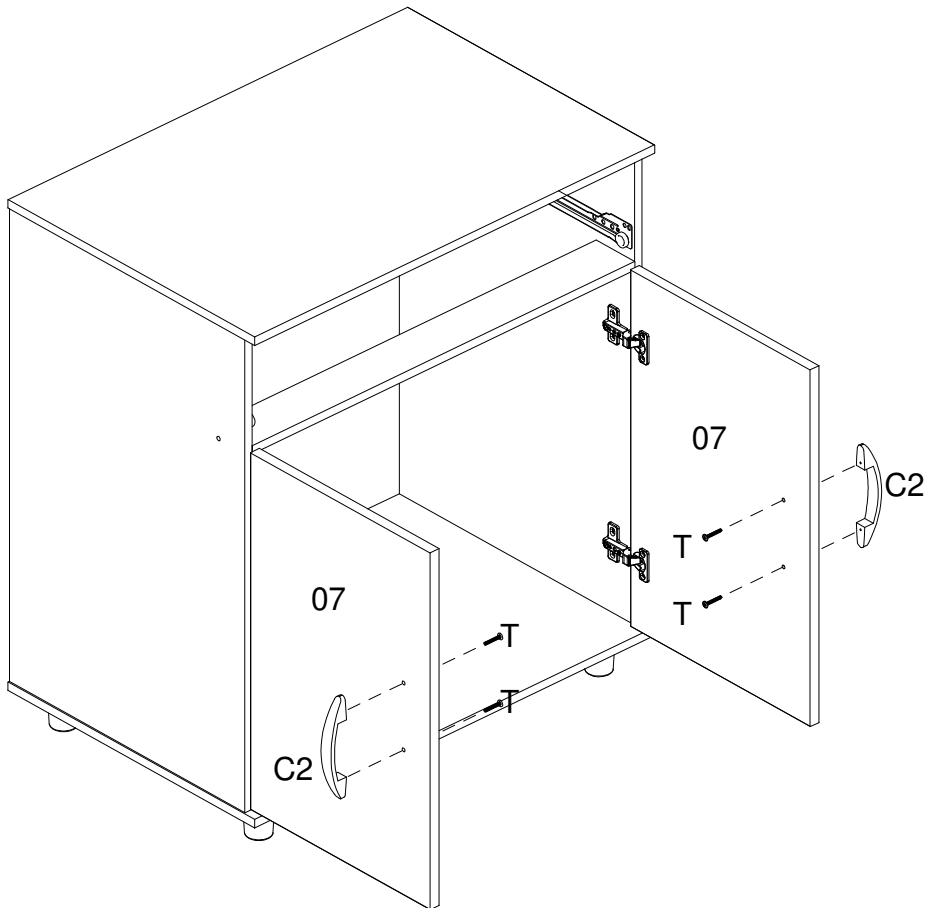

Horizontal Adjustment
Regulagem Horizontal
Ajuste Horizontal

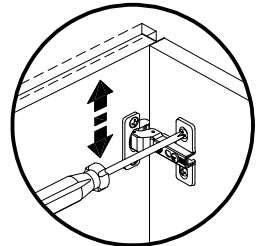

Vertical Adjustment
Regulagem Vertical
Ajuste Vertical

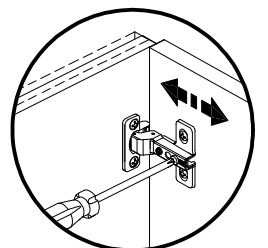

Depth Adjustment
Regulagem Profundidade
Ajuste Profundidad

11

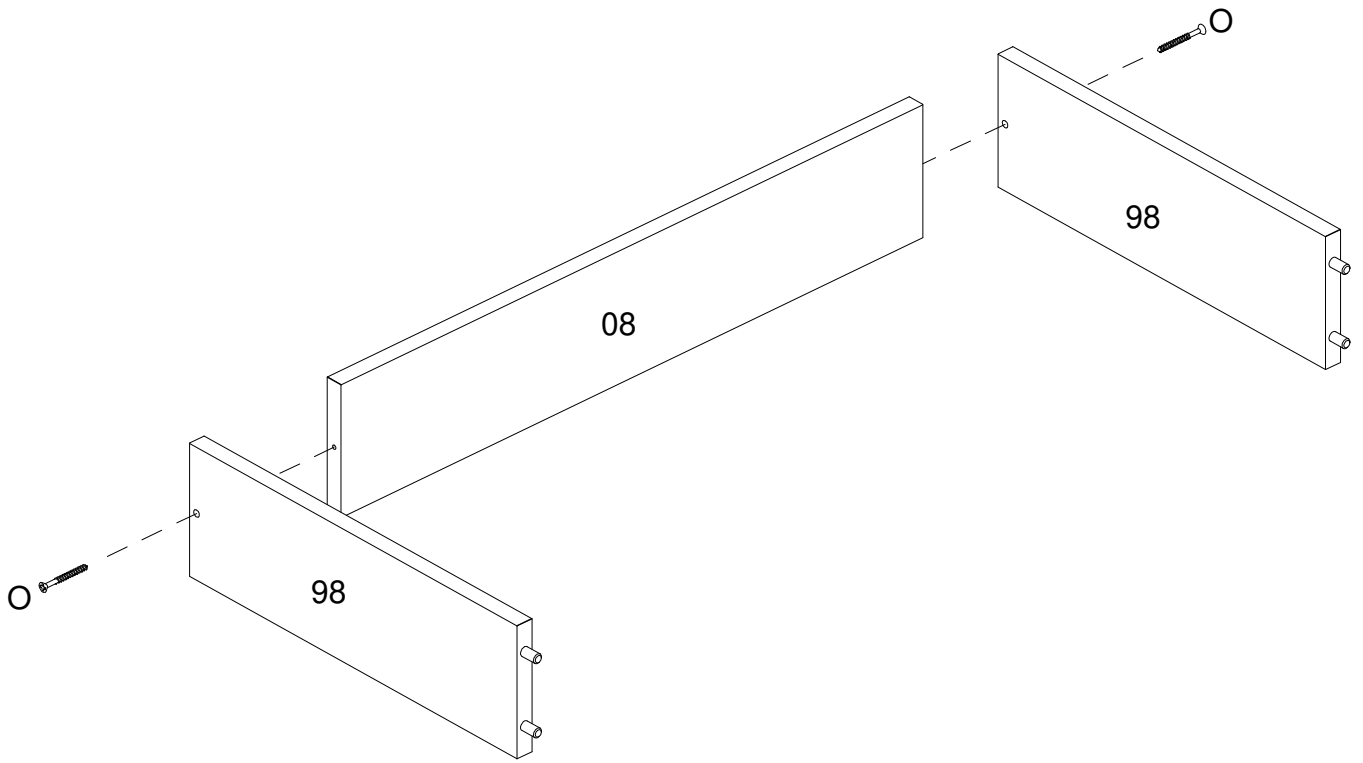

12

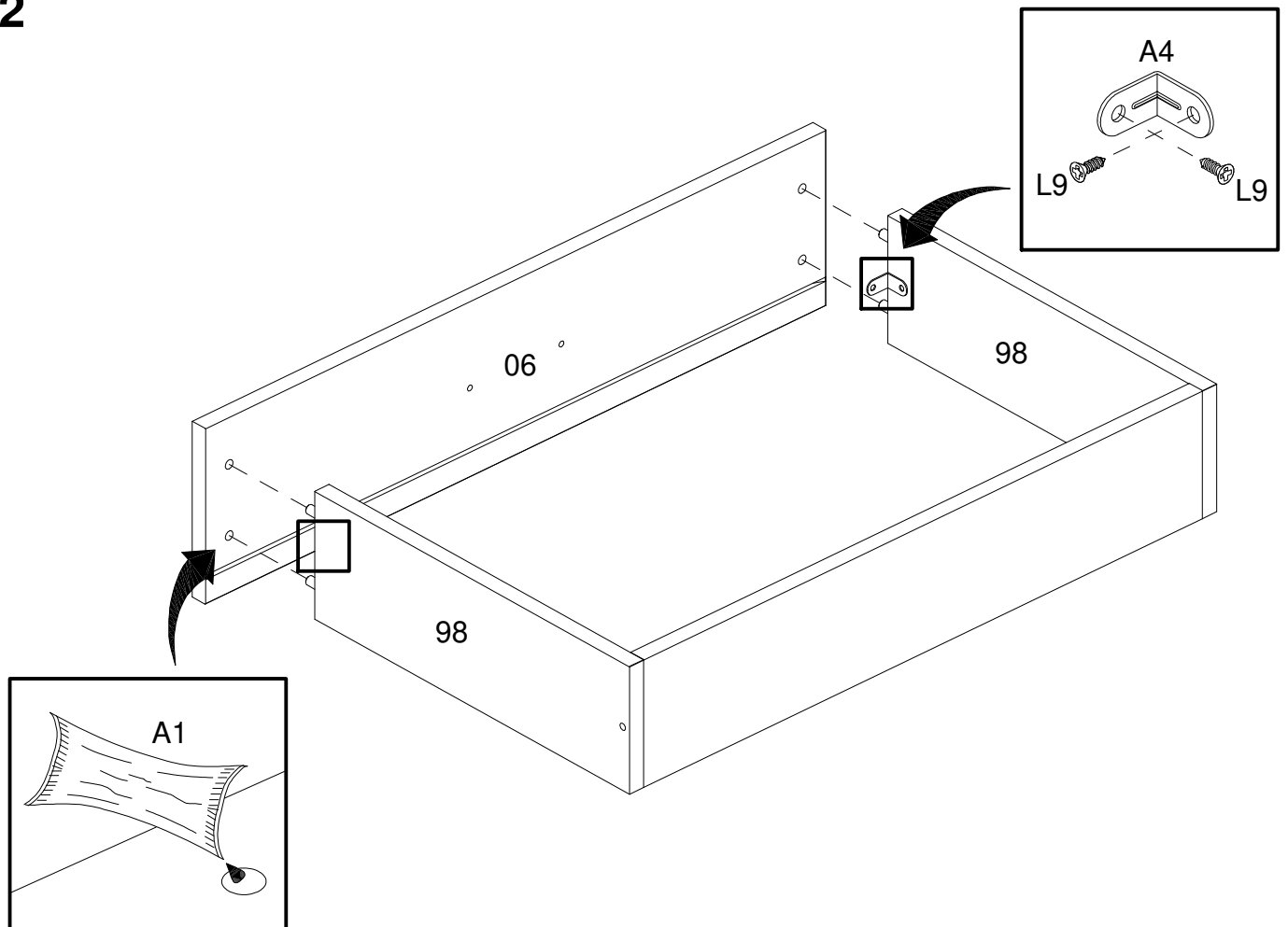

13

THE UNDERSIDE OF THE DRAWER
LADO INFERIOR DA GAVETA
PARTE INFERIOR DEL CAJÓN

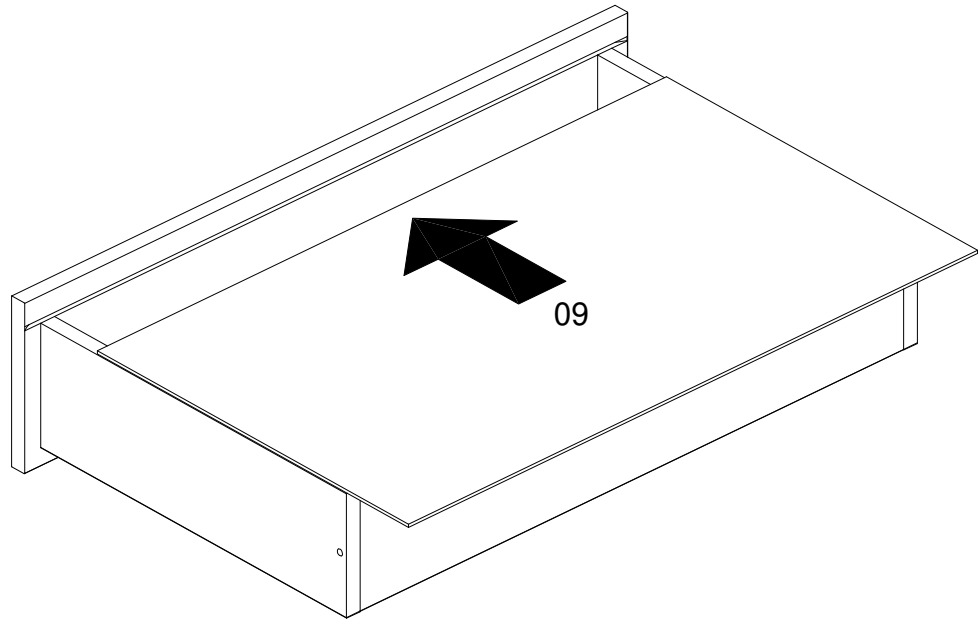

14

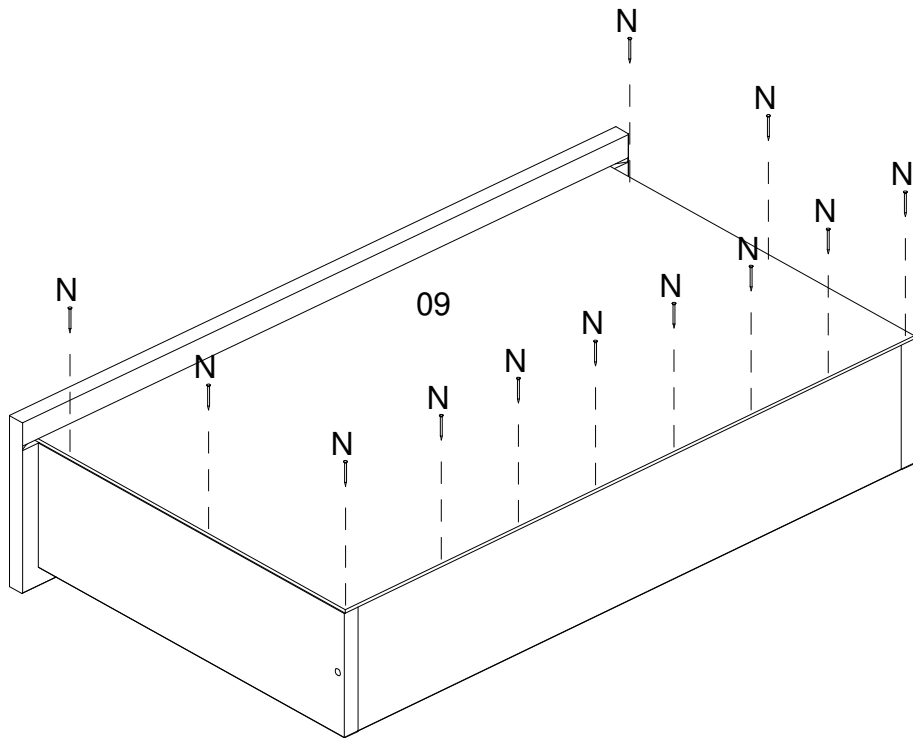

15

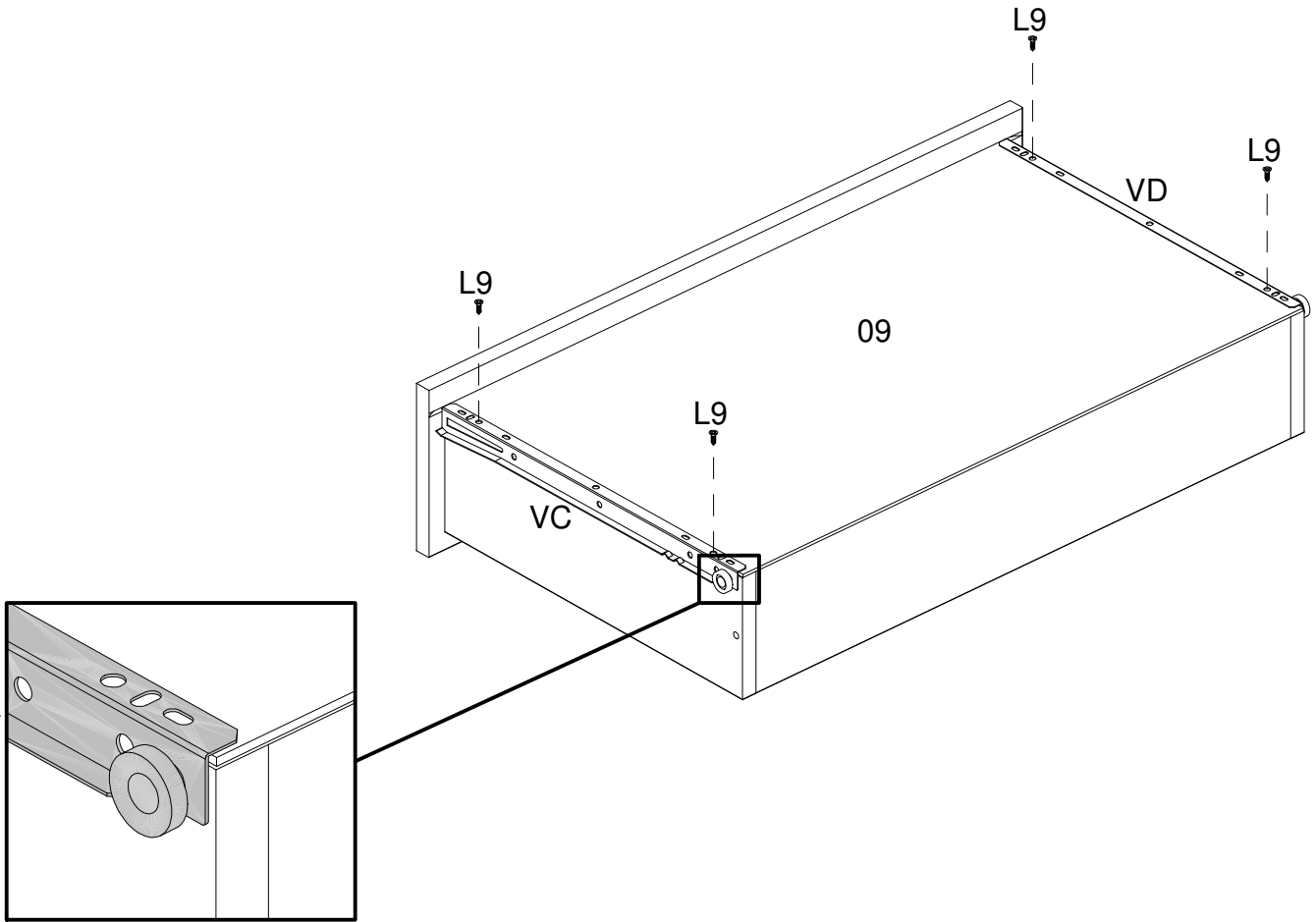

16

