

ASSEMBLY INSTRUCTIONS MANUAL DE MONTAGEM / INSTRUCCIONES DE ARMADO

Santa Mônica bookcase
Estante Santa Mônica
Biblioteca Santa Mônica

Reference 190721 | Revisão 02
Referência 190721 | Revisión 02

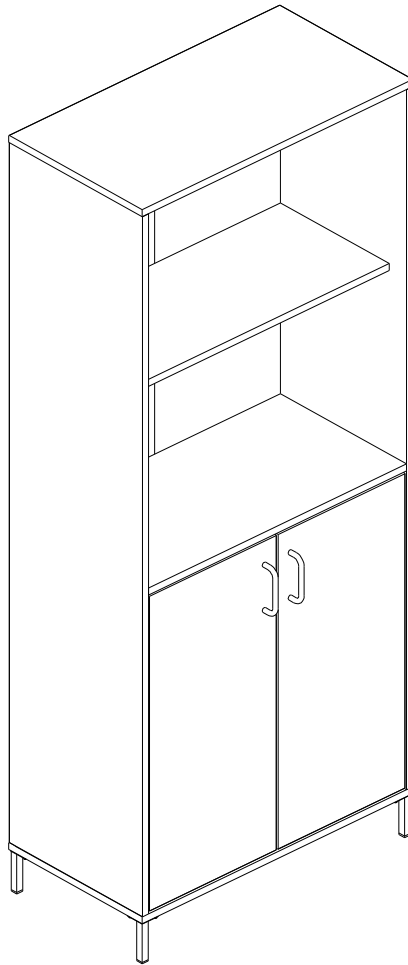

YOU WILL NEED / VOCÊ VAI PRECISAR DE / USTED NECESITARÁ

Tools not supplied / Ferramentas não fornecidas / Herramientas no incluidas

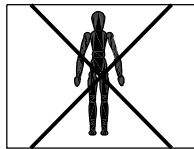

1 Person
1 Pessoa
1 Persona

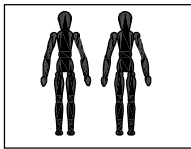

2 People
2 Pessoas
2 Personas

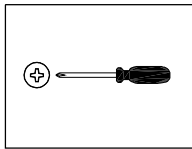

Screwdriver Phillips
Chave Phillips
Destornillador cruz

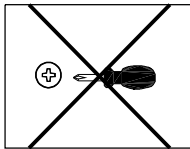

Small screwdriver Phillips
Chave Phillips Menor
Destornillador cruz menor

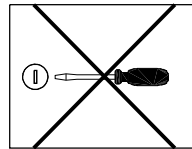

Screwdriver slotted
Chave fenda
Destornillador plano

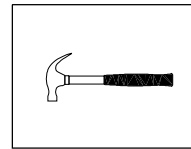

Hammer
Martelo
Martillo

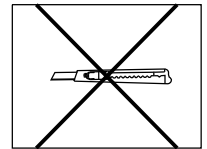

Stilet
Estilete
Estilete

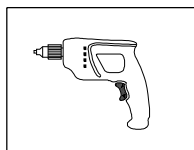

Drill machine
Furadeira
Taladro

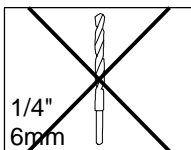

Drill bit
Broca
Taladro

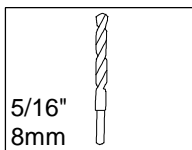

Drill bit
Broca
Taladro

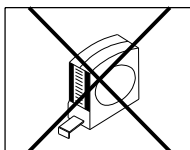

Measuring tape
Trena
Cinta de medición

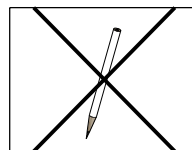

Pencil
Lápis
Lápiz

NOTES: The separation of the accessories before you start the assembly will facilitate the same. In case of doubt on the size of the screws and bolts, use the ruler to bottom of page 3.

NOTAS: A separação dos acessórios antes de iniciar a montagem facilitará a mesma. Em caso de dúvida no tamanho dos parafusos e cavilhas, utilize a régua ao final da página 3.

NOTAS: La separación de los accesorios antes de comenzar el armado facilitará el mismo. En caso de duda sobre el tamaño de los tornillos y taquetes, utilice la regla al pie de página 3.

MAXIMUM RECOMMENDED WEIGHT
BEING THIS EVENLY DISTRIBUTED

PESO MÁXIMO RECOMENDADO SENDO
ESTE DISTRIBUÍDO UNIFORMEMENTE

PESO MÁXIMO RECOMENDADO SIENDO
ESTE UNIFORMEMENTE DISTRIBUIDO

	LB	KG
A	22	10
B	11	5

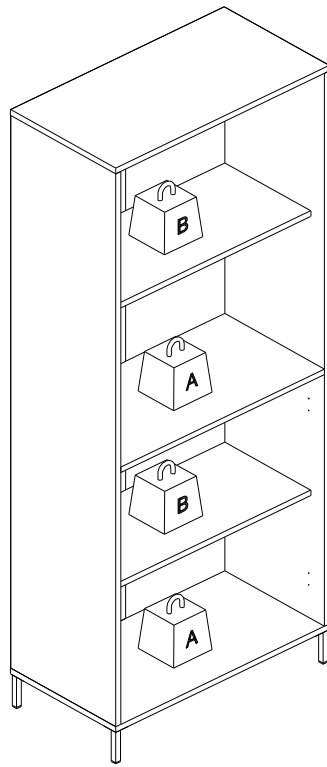





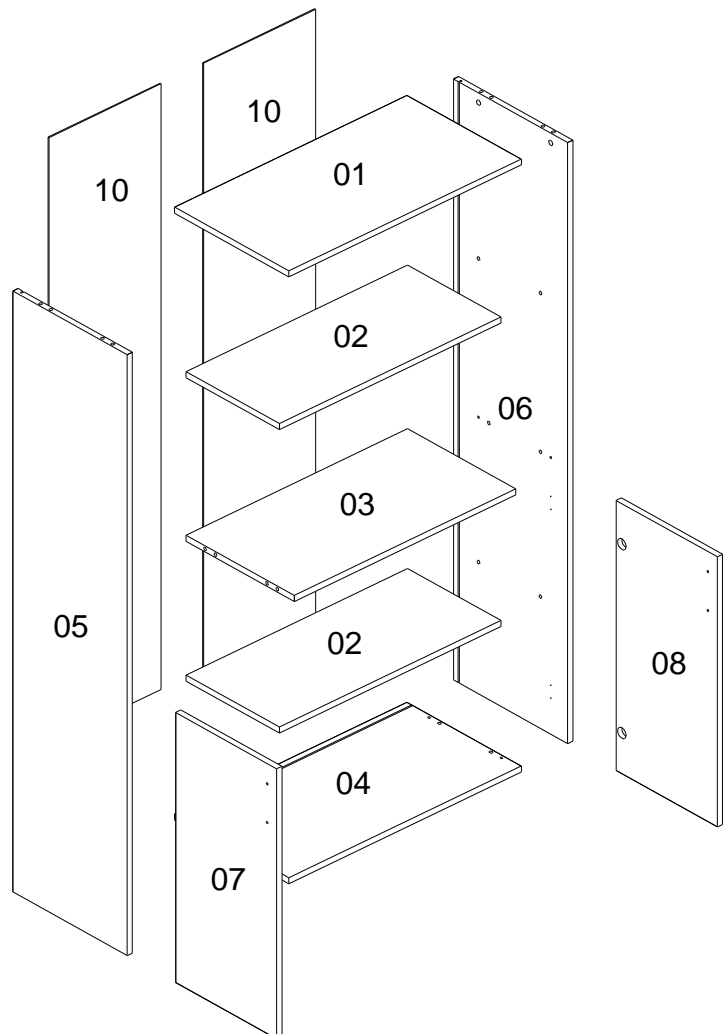



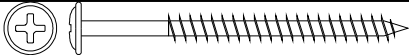

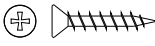
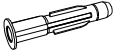



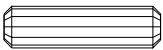

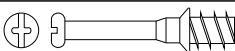
Nº	Measures Inches	Medidas cm	Qty./Qtd.
01	26 3/8 x 14 x 5/8	67 x 35,5 x 1,5	1
02	25 1/8 x 11 3/8 x 5/8	63,8 x 29 x 1,5	2
03	25 1/8 x 13 1/4 x 5/8	63,8 x 33,6 x 1,5	1
04	26 3/8 x 14 x 5/8	67 x 35,5 x 1,5	1
05	58 3/8 x 14 x 5/8	148,3 x 35,5 x 1,5	1
06	58 3/8 x 14 x 5/8	148,3 x 35,5 x 1,5	1
07	26 1/4 x 12 3/8 x 5/8	66,7 x 31,4 x 1,5	1
08	26 1/4 x 12 3/8 x 5/8	66,7 x 31,4 x 1,5	1
10	58 7/8 x 12 3/4 x 1/8	149,5 x 32,3 x 0,3	2

PARTS IDENTIFICATION
IDENTIFICAÇÃO DAS PEÇAS / IDENTIFICACIÓN DE LAS PIEZAS

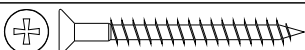

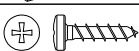
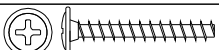
IDENTIFICATION OF ACCESSORIES IDENTIFICAÇÃO DOS ACESSÓRIOS/ IDENTIFICACIÓN DE ACCESORIOS

A		Flanged head screw / Parafuso flangeado / Tornillo de cabeza flangeada	5,0x60 mm	1
A6		"H" profile / Perfil "H" / Perfil "H"	-	1
A8		Flat head screw / Parafuso chato / Tornillo de cabeza plana	3,5x20 mm	10
B3		Bushing / Bucha expansiva / Tapón	8x50 mm	1
B8		Shelf bracket / Suporte de prateleira / Suporte de repisa	10x15 mm	2
D5		Hinge shim / Calço dobradiça / Bisagra de calce	-	4
D6		Metal hinge super high / Dobradiça super alta / Bisagra alta	26 mm	4
E		Wooden dowel / Cavilha / Taquete	8x30 mm	12
E3		Shelf bracket / Suporte de prateleira / Suporte de repisa	8x7 mm	8
E9		Strap / Cinta / Correea	-	1
J		Simple minifix screw / Haste minifix simples / Tornillo minifix simple	-	8
L		Drum lock / Tambor minifix / Tambor minifix	12 mm	8
L13		Foot / Pé tubular / Pie	87x15 mm	4
M		Bore patch adhesive / Tapa furo adesivo / Tapones adhesivo	-	4
O		Flat head screw / Parafuso chato / Tornillo de cabeza plana	4,5x45 mm	4
o1		Triangular support / Suporte triangular / Soporte triangular	-	10
S		Pan head screw / Parafuso panela / Tornillo de pan	3,5x14 mm	31
T		Flanged head screw / Parafuso flangeado / Tornillo de cabeza flangeada	3,5x25 mm	4
W7		Handle / Puxador Goleira / Tirador	96 mm	2



PRE-ASSEMBLE
PRÉ-MONTAGEM / PRE ARMADO

01

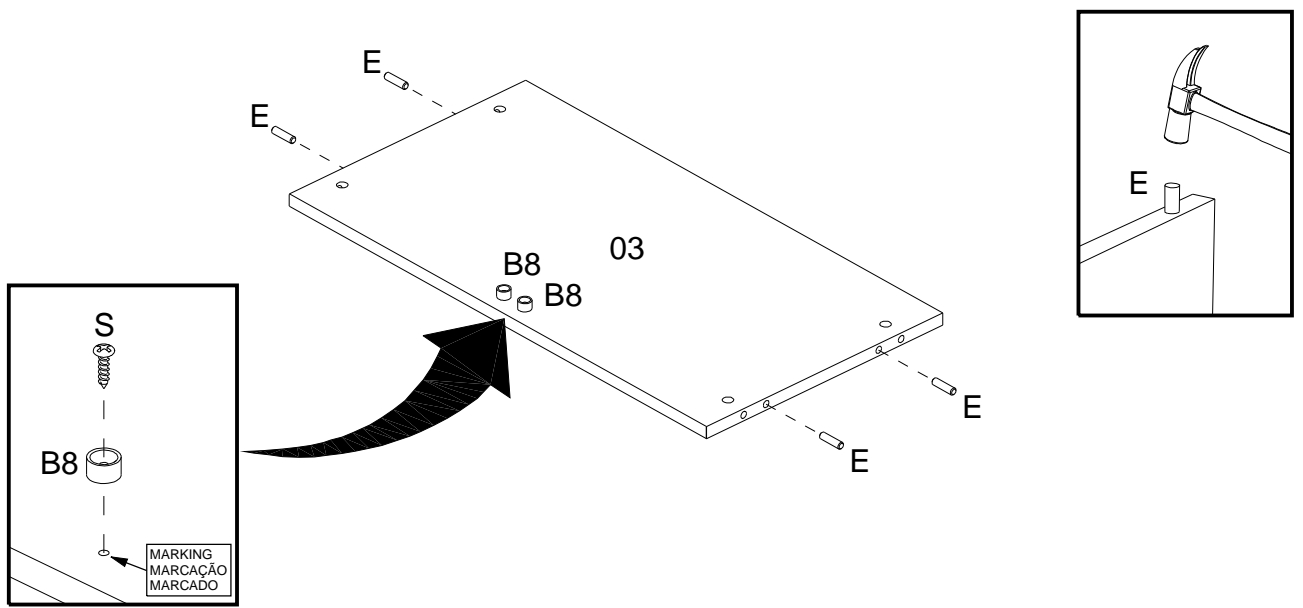

02

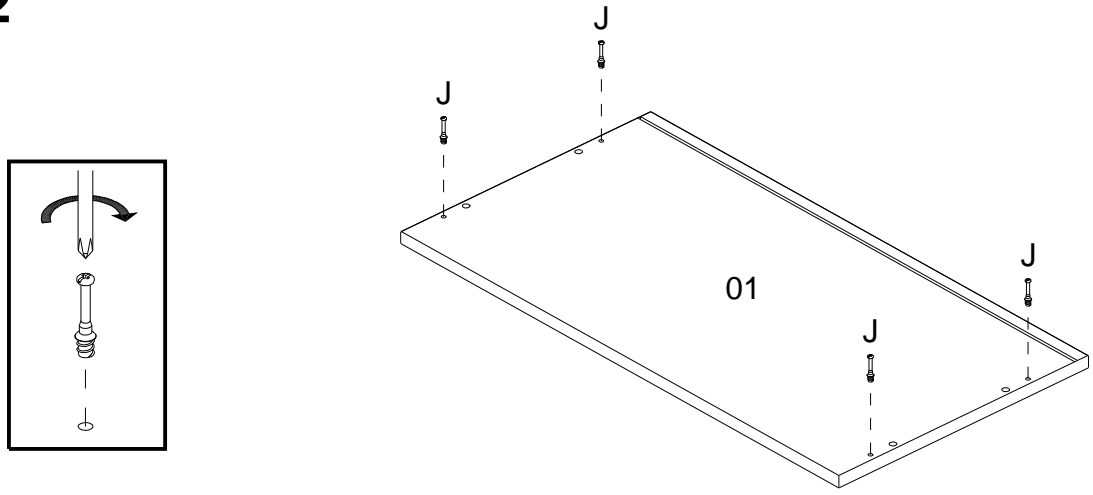

03

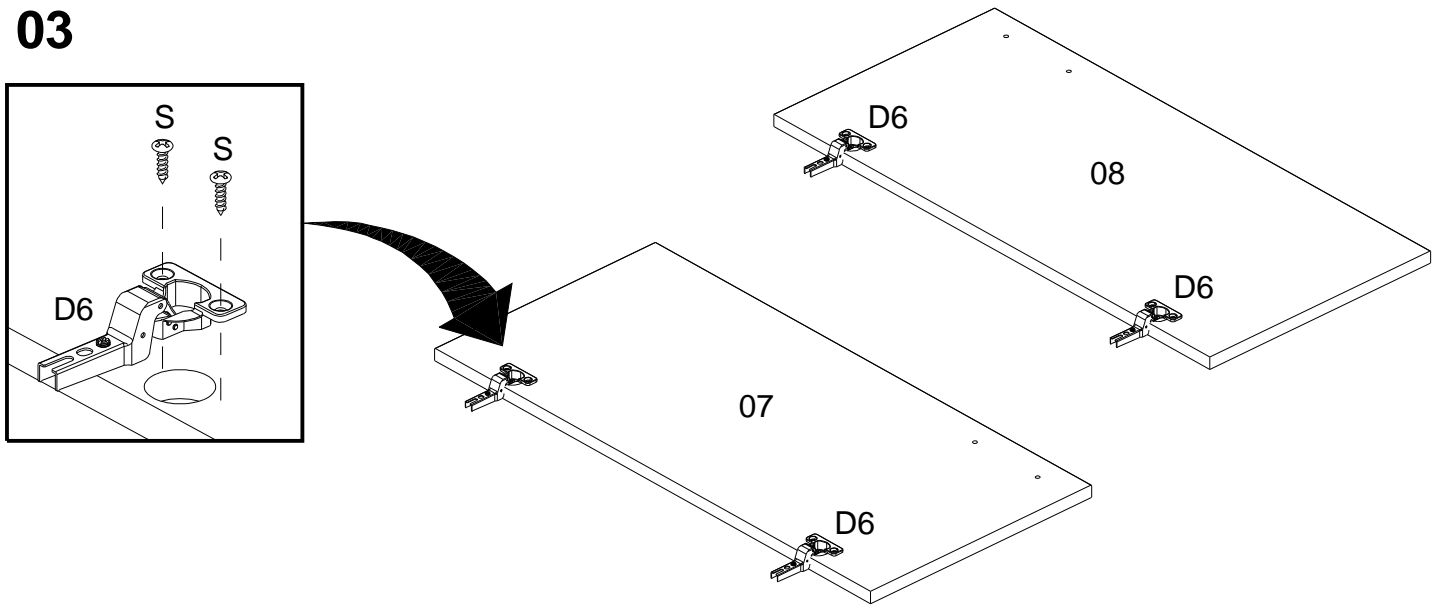

04

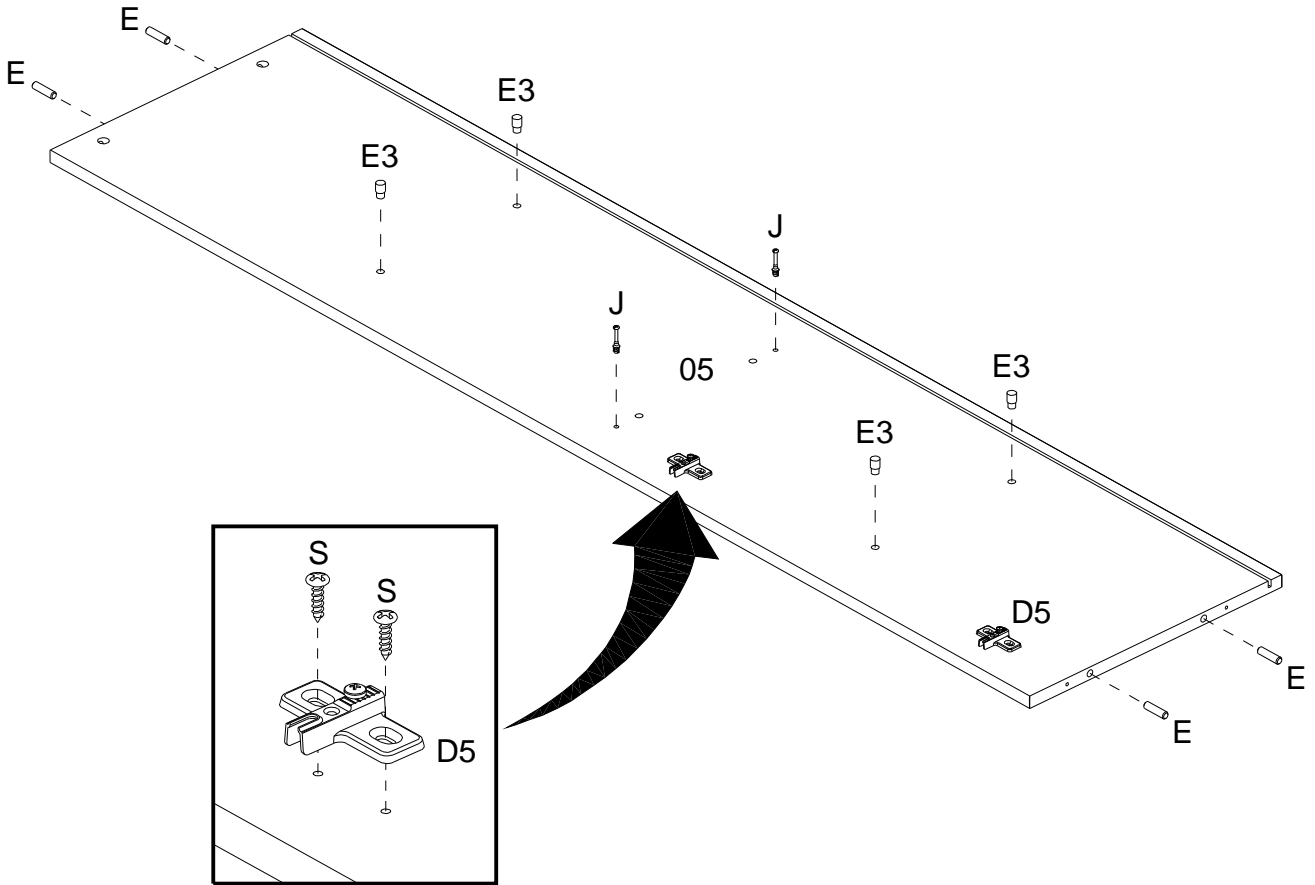

05

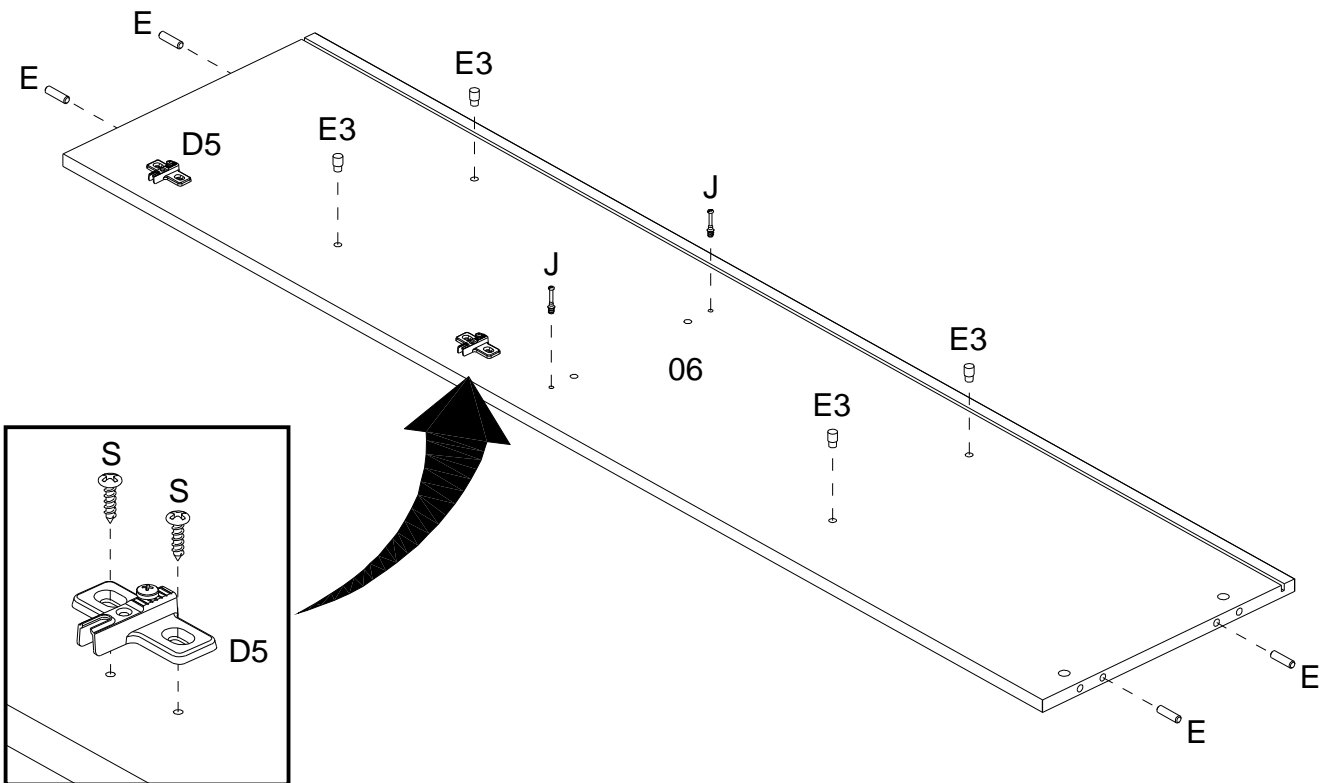

ASSEMBLY
MONTAGEM / ARMADO

06

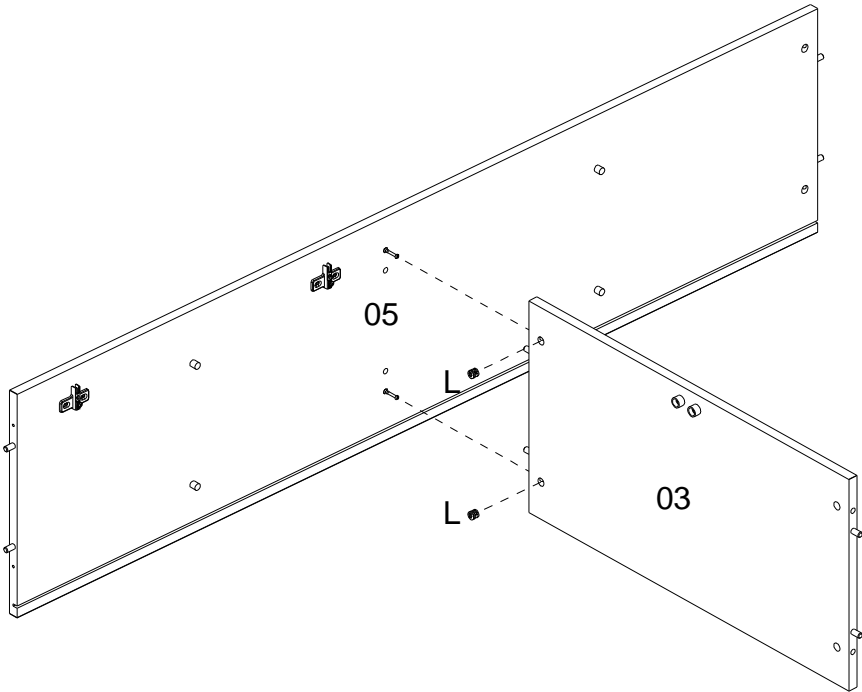
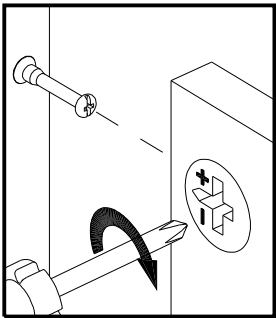

07

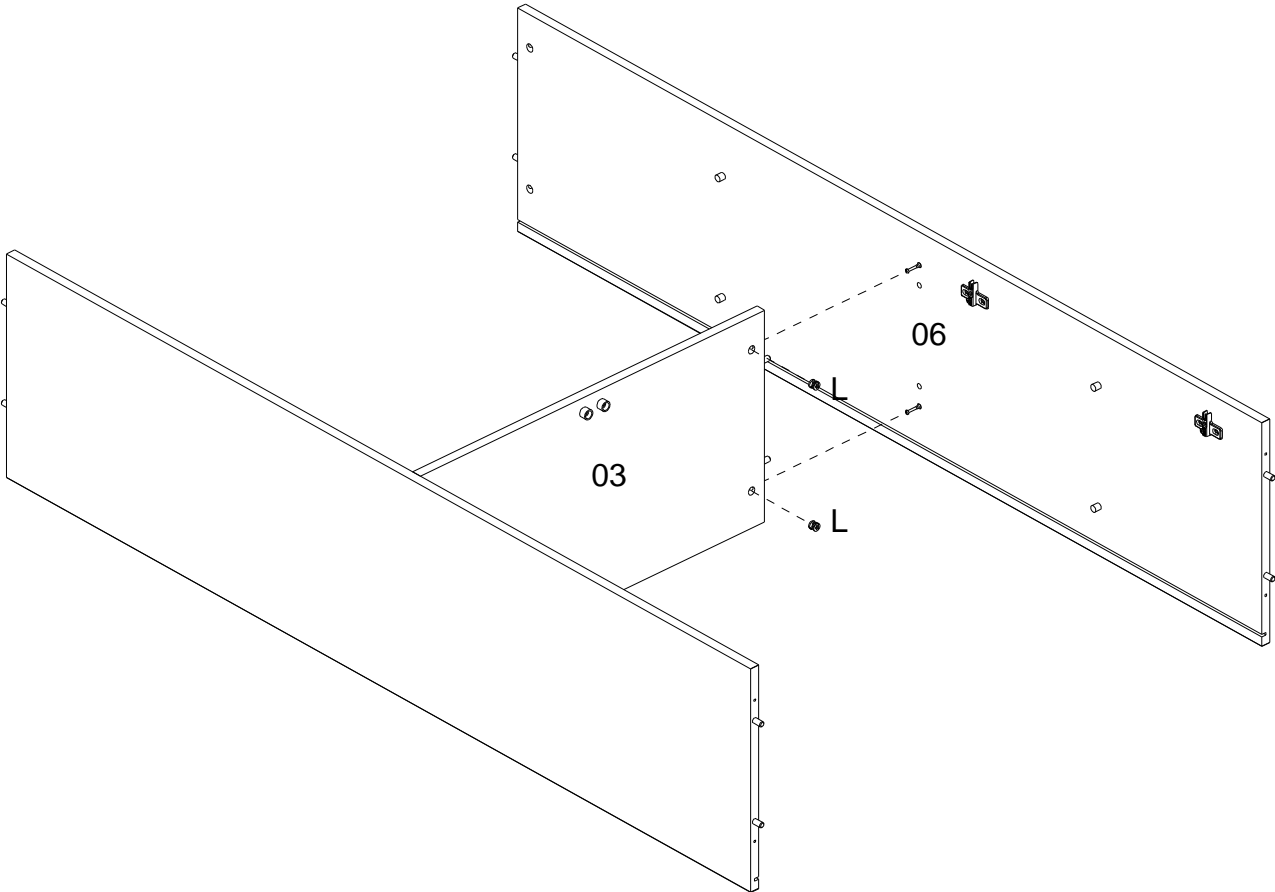

08

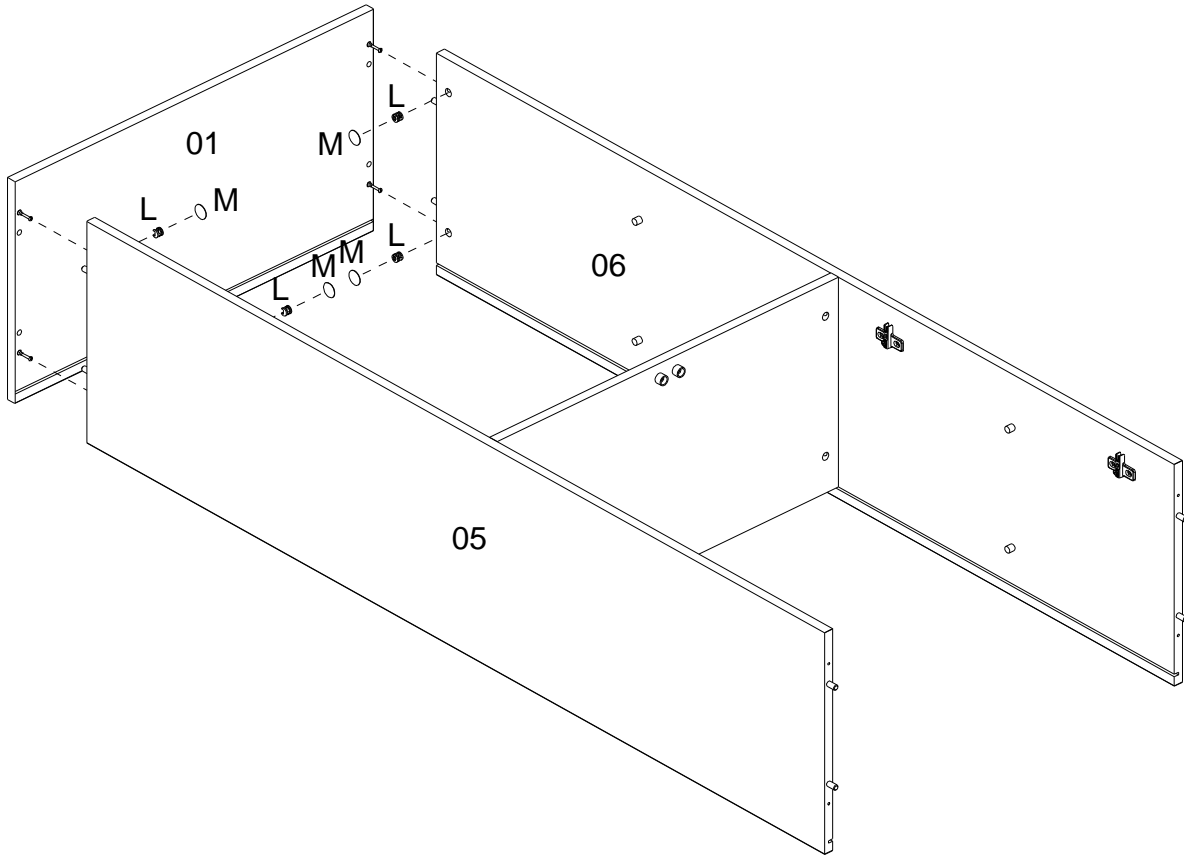

09

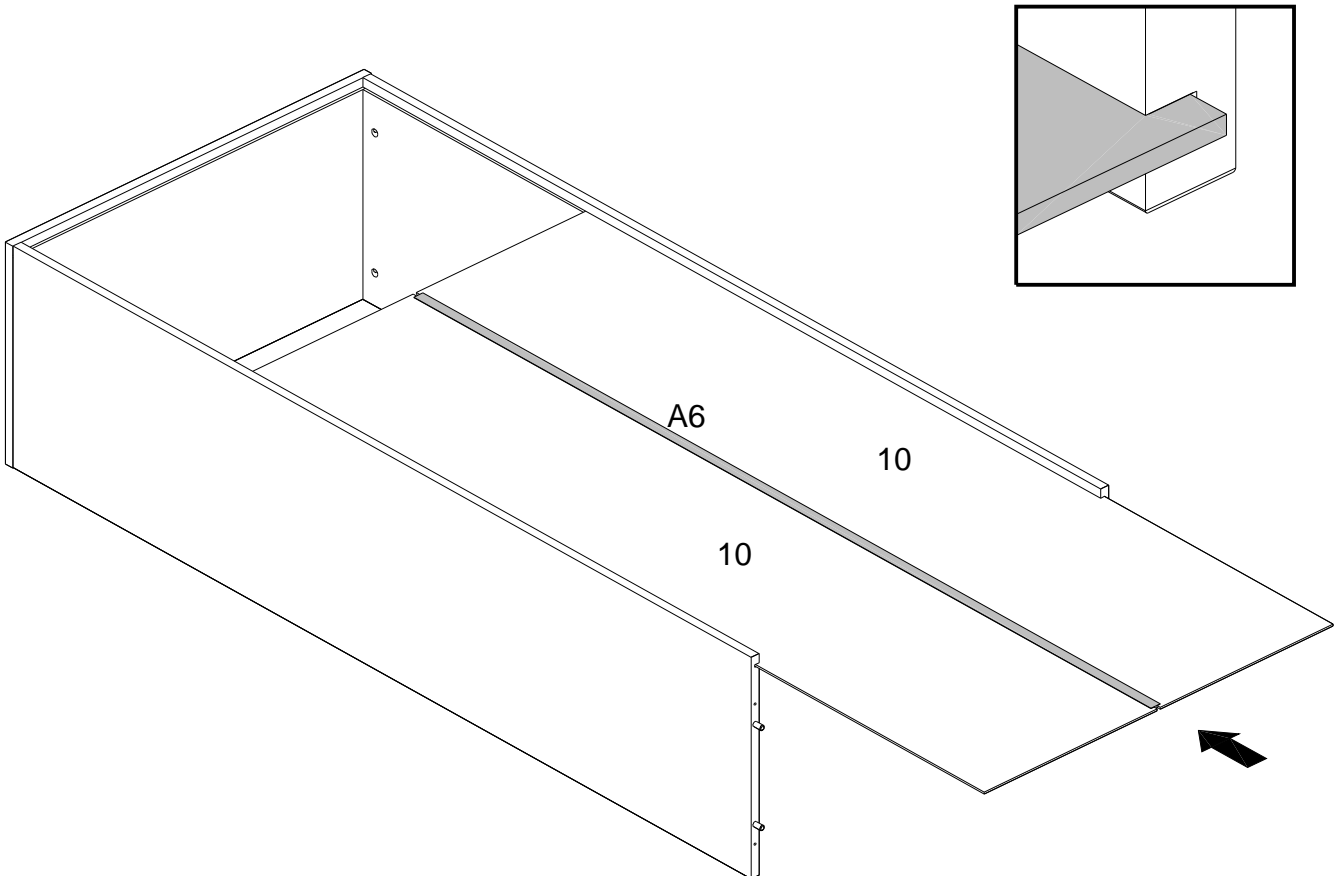

10

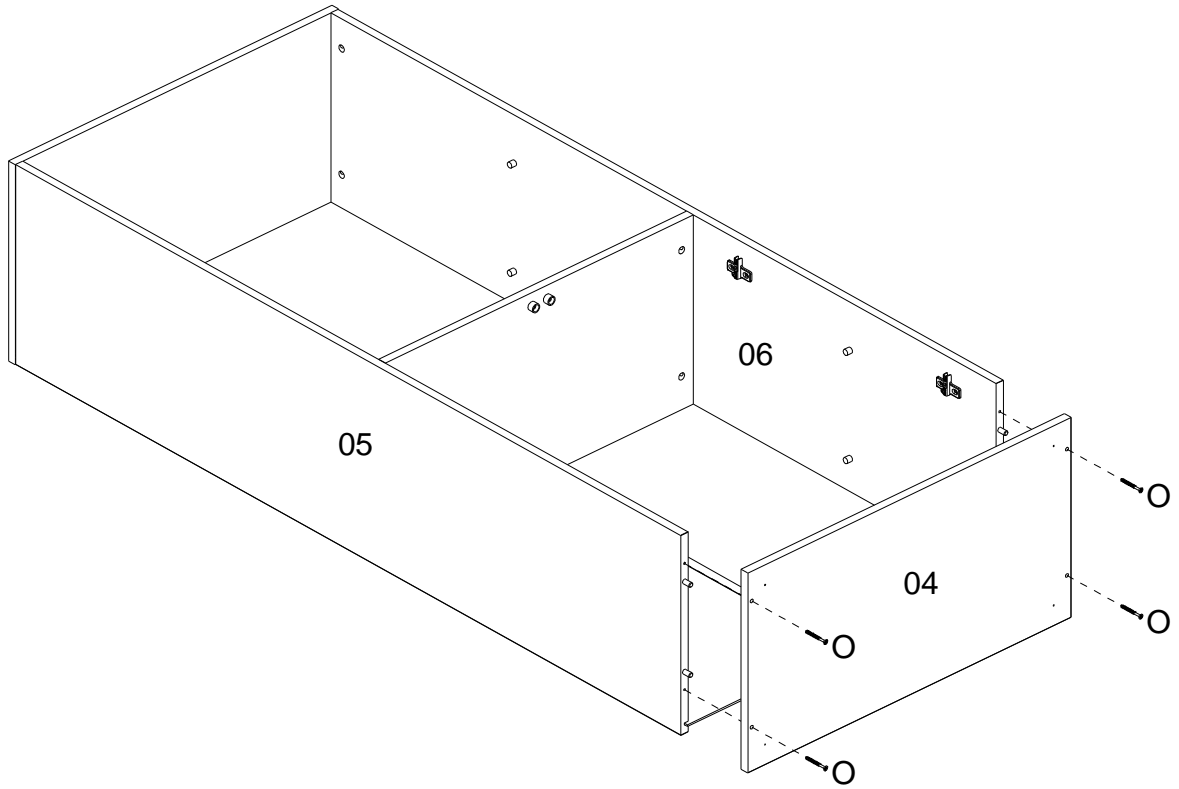

11

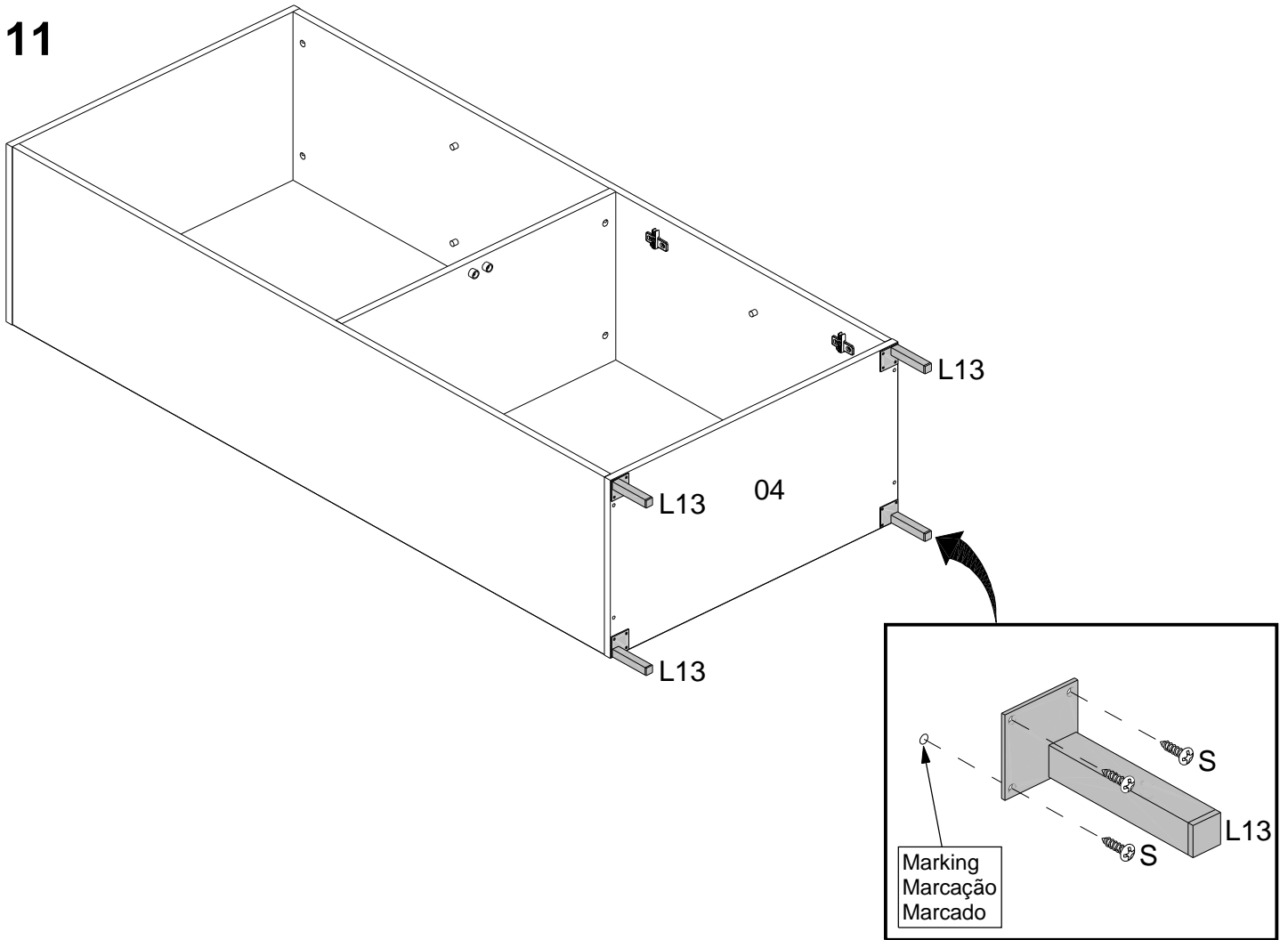

12

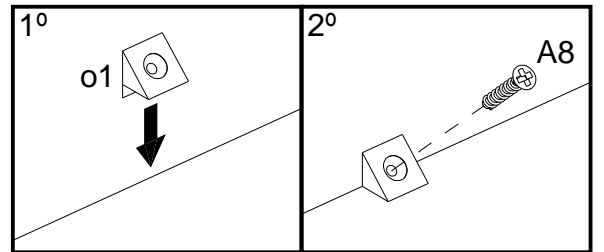
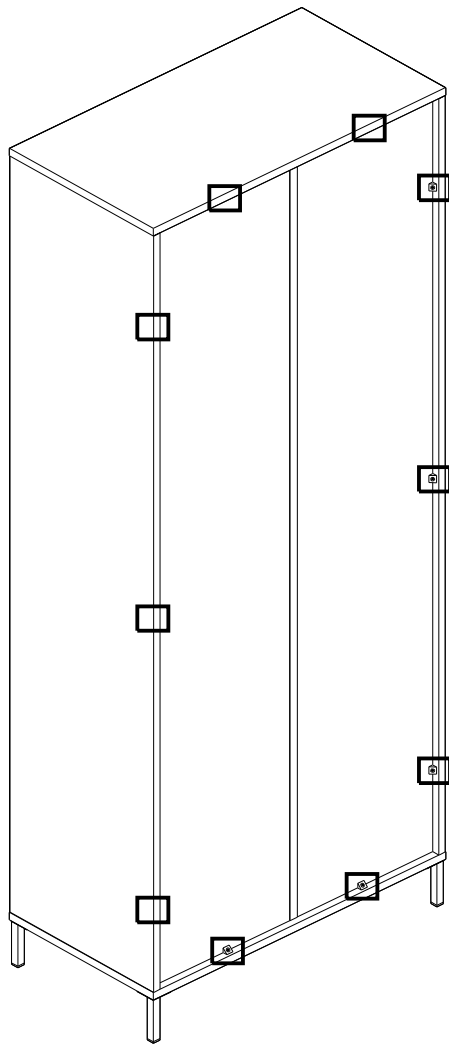

13

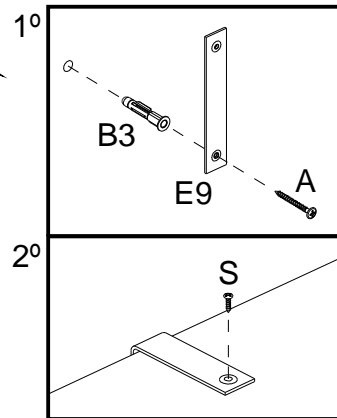
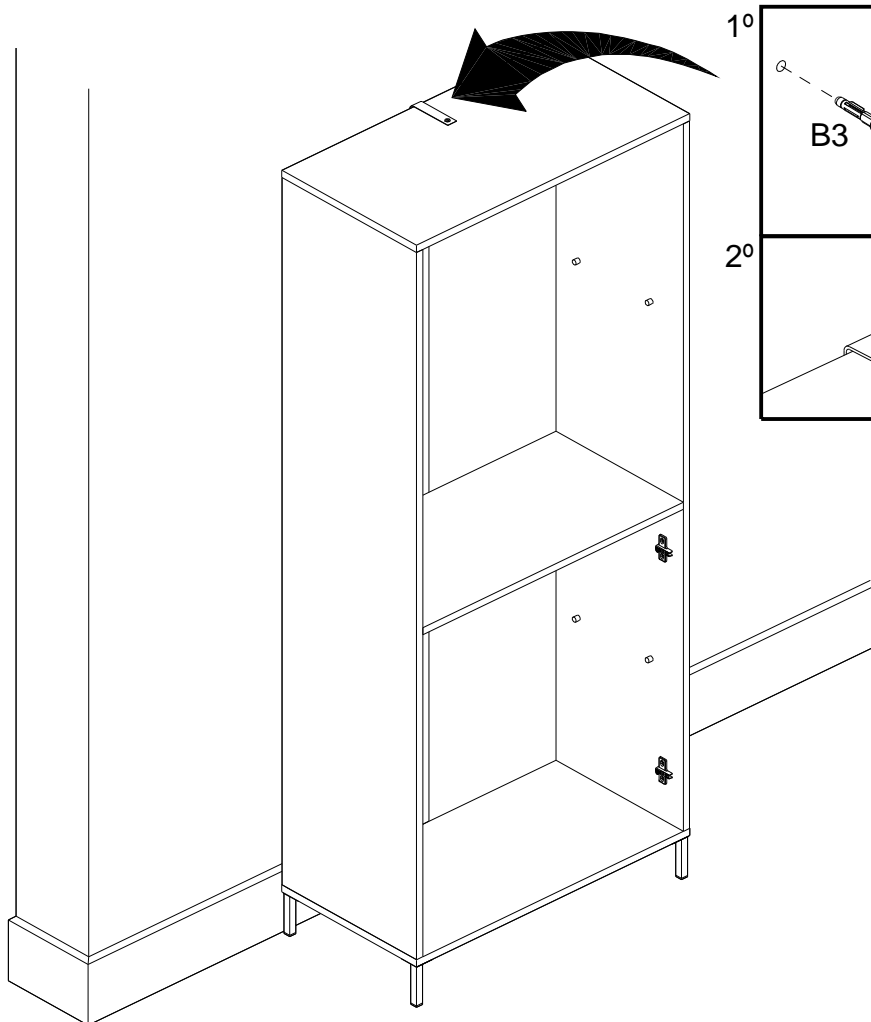

14

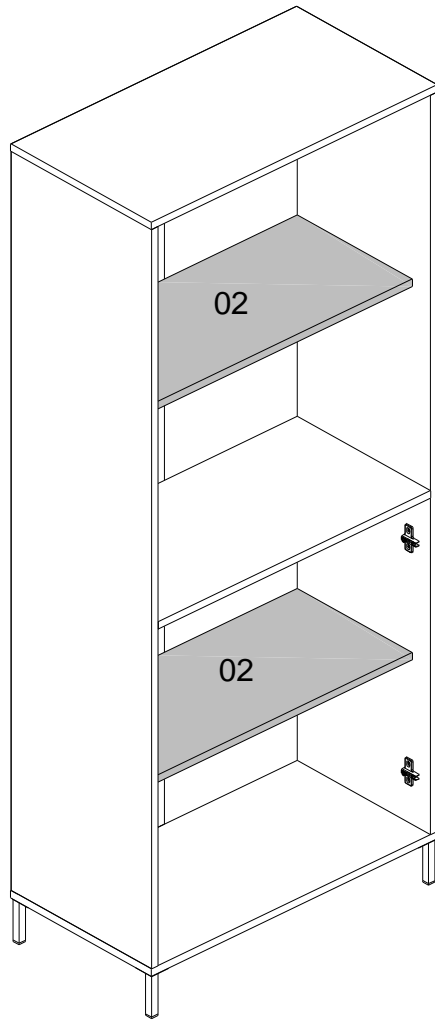

15

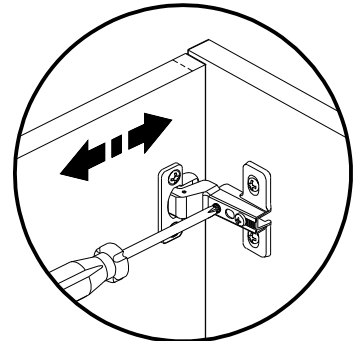
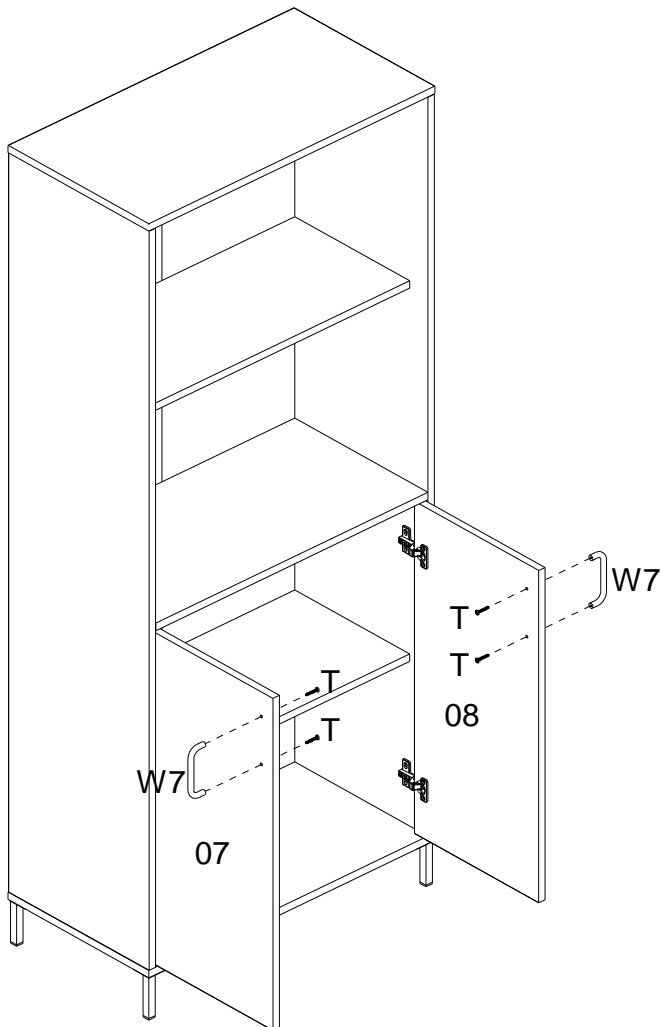

Horizontal Adjustment
Regulagem Horizontal
Ajuste Horizontal

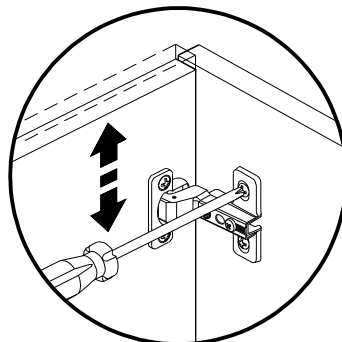

Vertical Adjustment
Regulagem Vertical
Ajuste Vertical

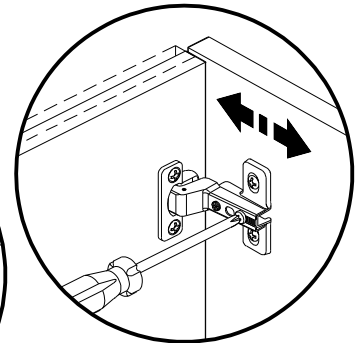

Depth Adjustment
Regulagem Profundidade
Ajuste Profundidad