

MANUAL DE MONTAGEM

ASSEMBLY INSTRUCTIONS / INSTRUCCIONES DE ARMADO

APARADOR CAYMAN 900MM
 CAYMAN side board 35" 3/8
 Aparador CAYMAN 900MM

Código **170697** | Revisão 00

Português
 English
 Español

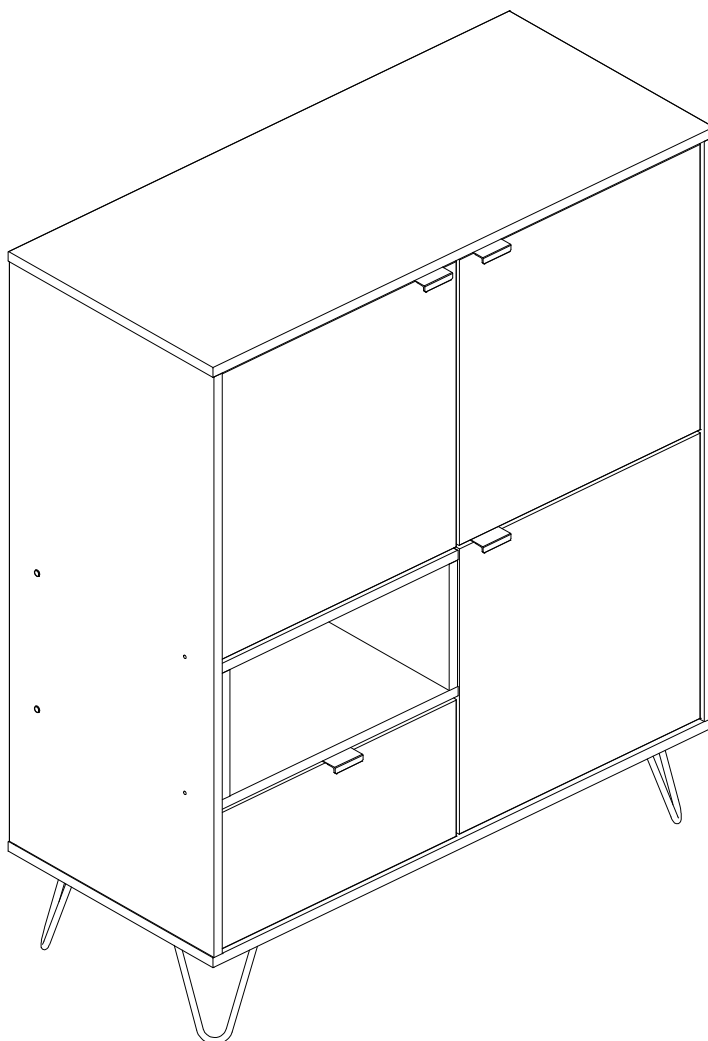

VOCÊ VAI PRECISAR DE / YOU WILL NEED / USTED NECESITARÁ

Ferramentas não fornecidas / Tools not supplied / Herramientas no incluidas

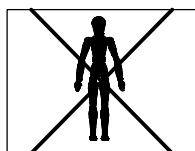

1 Pessoa
 1 Person
 1 Persona

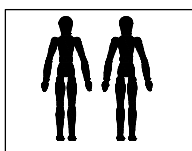

2 Pessoas
 2 People
 2 Personas

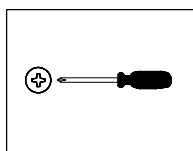

Chave Phillips
 Screwdriver Phillips
 Destornillador cruz

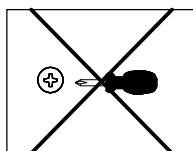

Chave Phillips Menor
 Small screwdriver Phillips
 Destornillador cruz menor

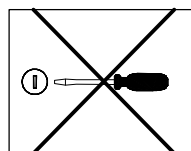

Chave fenda
 Screwdriver slotted
 Destornillador plano

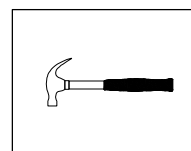

Martelo
 Hammer
 Martillo

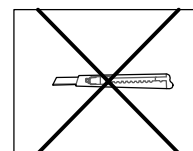

Estilete
 Stylet
 Estilete

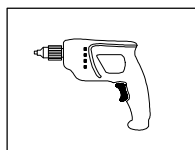

Furadeira
 Drill machine
 Taladro

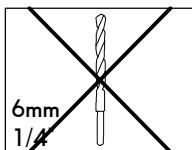

Broca
 Drill bit
 Taladro

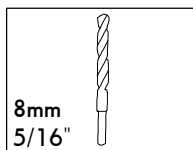

Broca
 Drill bit
 Taladro

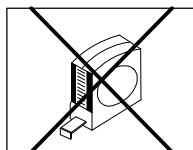

Trena
 Measuring tape
 Cinta de medición

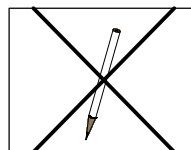













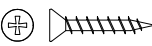
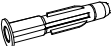





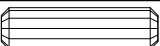
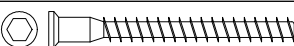

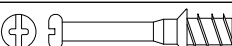
Lápis
 Pencil
 Lápiz

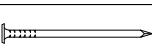
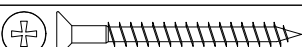
NOTAS: A separação dos acessórios antes de iniciar a montagem facilitará a mesma. Em caso de dúvida no tamanho dos parafusos e cavilhas, utilize a régua ao final da página 2.

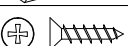
NOTES: The separation of the accessories before you start the assembly will facilitate the same. In case of doubt on the size of the screws and bolts, use the ruler to bottom of page 2.

NOTAS: La separación de los accesorios antes de comenzar el armado facilitará el mismo. En caso de duda sobre el tamaño de los tornillos y taquetes, utilice la regla al pie de página 2.

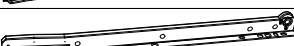
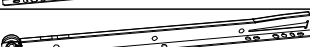
IDENTIFICAÇÃO DOS ACESSÓRIOS/ IDENTIFICATION OF ACCESSORIES/ IDENTIFICACIÓN DE ACCESORIOS

A		Parafuso flangeado / Flanged head screw / Tornillo de cabeza flangeada	5,0x60 mm	1
A1		Cola / Glue / Pegamento	13 g	1
A8		Parafuso chato / Flat head screw / Tornillo de cabeza plana	3,5x20 mm	6
B3		Bucha expansiva / Bushing / Tapón	8x50 mm	1
B7		Suporte de metal / Metallic bracket / Suporte de metal	-	1
B8		Suporte de prateleira / Shelf bracket / Suporte de repisa	10x15 mm	1
C1		Garra de metal / Metal claw / Garra metal	-	5
D5		Calço dobradiça / Hinge shim / Bisagra de calce	-	6
D6		Dobradiça super alta / Metal hinge super high / Bisagra alta	26 mm	6
E		Cavilha / Wooden dowel / Taquete	8x30 mm	44
G		Parafuso estrutural / Structural screw / Tornillo estructural	5,0x50 mm	10
H		Chave allen / Allen key / Llave allen	3 mm	1
I		Tampa parafuso estrutural / Structural screw cover / Tapa tornillo estructural	-	10
J		Haste minifix simples / Simple minifix screw / Tornillo minifix simple	-	10
L		Tambor minifix / Drum lock / Tambor minifix	12 mm	10
M		Tapa furo adesivo / Bore patch adhesive / Tapones adhesivo	-	10
N		Prego / Nail / Clavo	10 x10	5
O		Parafuso chato / Flat head screw / Tornillo de cabeza plana	4,5x45 mm	8
o1		Suporte triangular / Triangular support / Soporte triangular	-	6
P5		Parafuso chato especial / Flat head screw / Tornillo de cabeza plana	3,5x14 mm	16
S		Parafuso panela / Pan head screw / Tornillo de pan	3,5x14 mm	43
VA		Corrediça lateral esquerda / Metallic slide the left field / Corredera lateral izquierda	350 mm	1
VB		Corrediça lateral direita / Metallic slide the right field / Corredera lateral derecha	350 mm	1
VC		Corrediça gaveta esquerda / Drawer slide left / Corredera izquierda cajón	350 mm	1
VD		Corrediça gaveta direita / Drawer slide right / Corredera derecha cajón	350 mm	1
X4		Puxador stile / Handle / Tirador	32 mm	4
Y8		Pé Aramado / Wire foot / Pie de alambre	147 mm	4



IDENTIFICAÇÃO DAS PEÇAS / PARTS IDENTIFICATION/ IDENTIFICACIÓN DE LAS PIEZAS

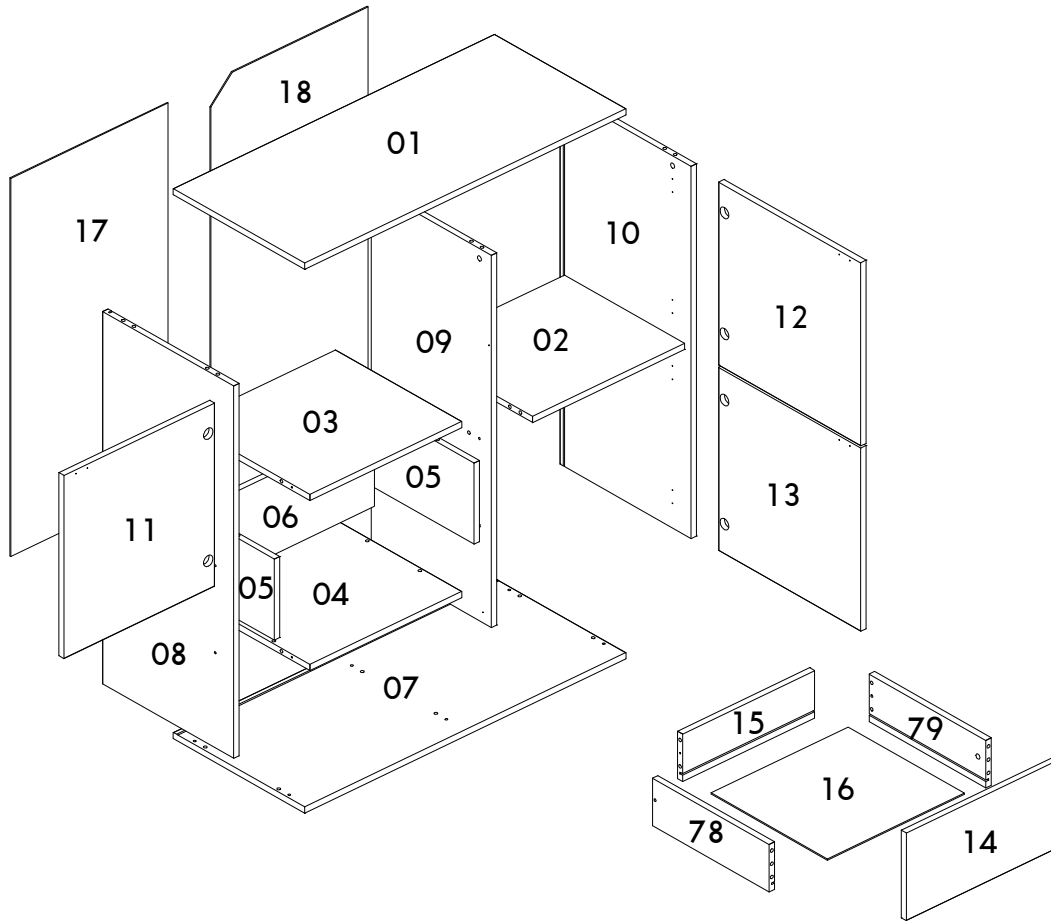

Número / Number / Número	Medidas / Measures / Medidas		Qtd. / Qty. / Qtd.
	cm	inches	
01	90 x 40 x 1,5	35" 3/8 x 15" 3/4 x 5/8	1
02	42,6 x 36,6 x 1,5	16" 3/4 x 14" 3/8 x 5/8	1
03	42,5 x 38,4 x 1,5	16" 3/4 x 15" 1/8 x 5/8	1
04	42,5 x 38,4 x 1,5	16" 3/4 x 15" 1/8 x 5/8	1
05	19,6 x 38,4 x 1,5	7" 3/4 x 15" 1/8 x 5/8	2
06	19,6 x 39,4 x 1,5	7" 3/4 x 15" 1/2 x 5/8	1
07	90 x 40 x 1,5	35" 3/8 x 15" 3/4 x 5/8	1
08	90 x 40 x 1,5	35" 3/8 x 15" 3/4 x 5/8	1
09	90 x 36,6 x 1,5	35" 3/8 x 14" 3/8 x 5/8	1
10	90 x 40 x 1,5	35" 3/8 x 15" 3/4 x 5/8	1
11	44,3 x 42,2 x 1,5	17" 1/2 x 16" 5/8 x 5/8	1
12	44,3 x 43,3 x 1,5	17" 1/2 x 17" 1/8 x 5/8	1
13	44,3 x 43,3 x 1,5	17" 1/2 x 17" 1/8 x 5/8	1
14	21,2 x 42,2 x 1,5	8" 3/8 x 16" 5/8 x 5/8	1
15	37 x 11,5 x 1,5	14" 1/2 x 4" 1/2 x 5/8	1
16	38,4 x 35,4 x 0,3	15" 1/8 x 14" x 1/8	1
17	91,4 x 44 x 0,3	36" x 17" 3/8 x 1/8	1
18	91,4 x 44 x 0,3	36" x 17" 3/8 x 1/8	1
78	35,5 x 11,5 x 1,5	14" x 4" 1/2 x 5/8	1
79	35,5 x 11,5 x 1,5	14" x 4" 1/2 x 5/8	1

01

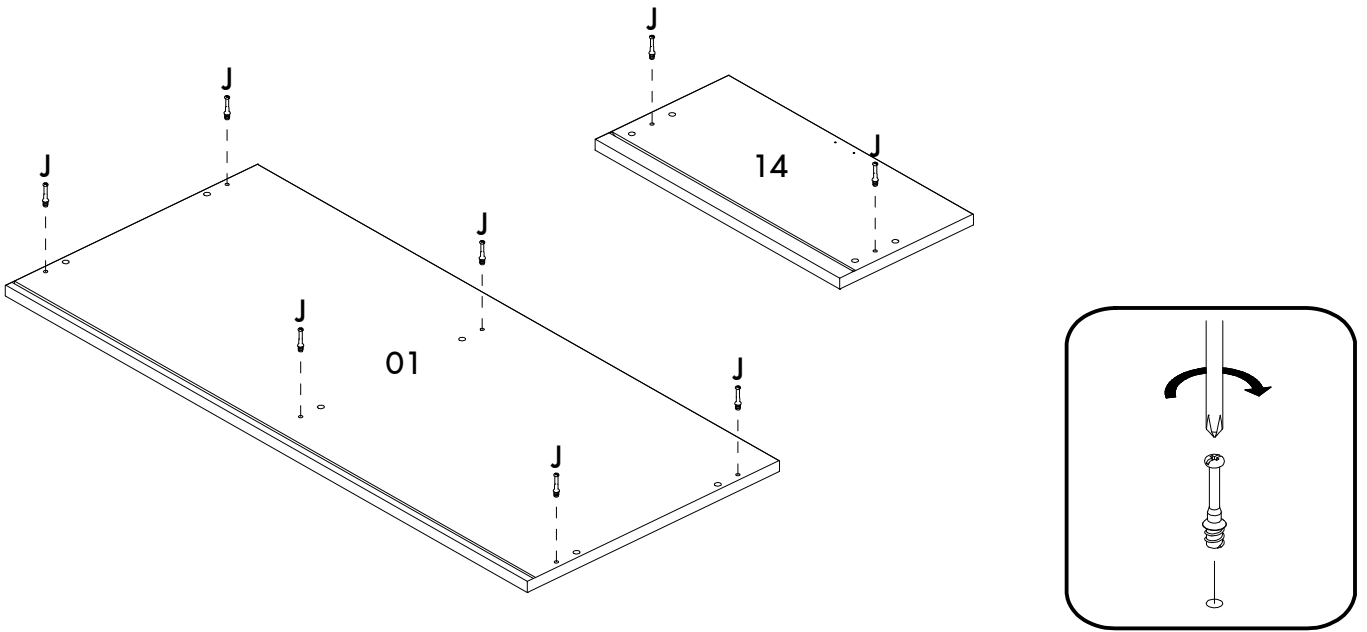

02

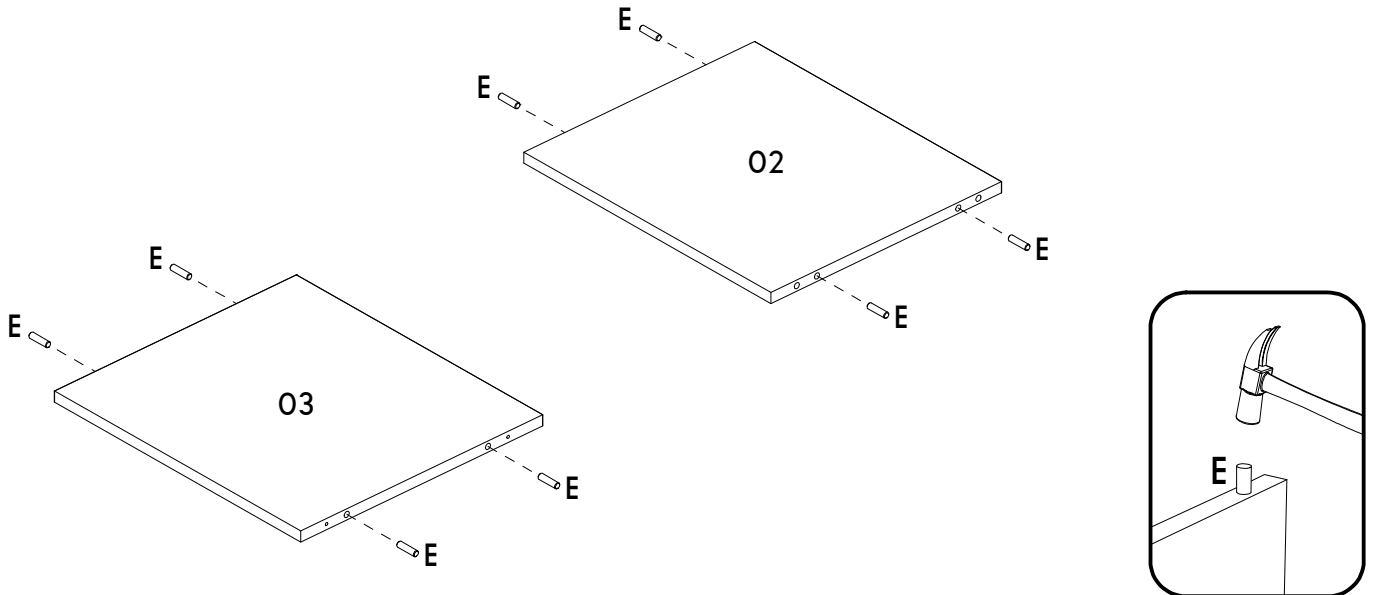

03

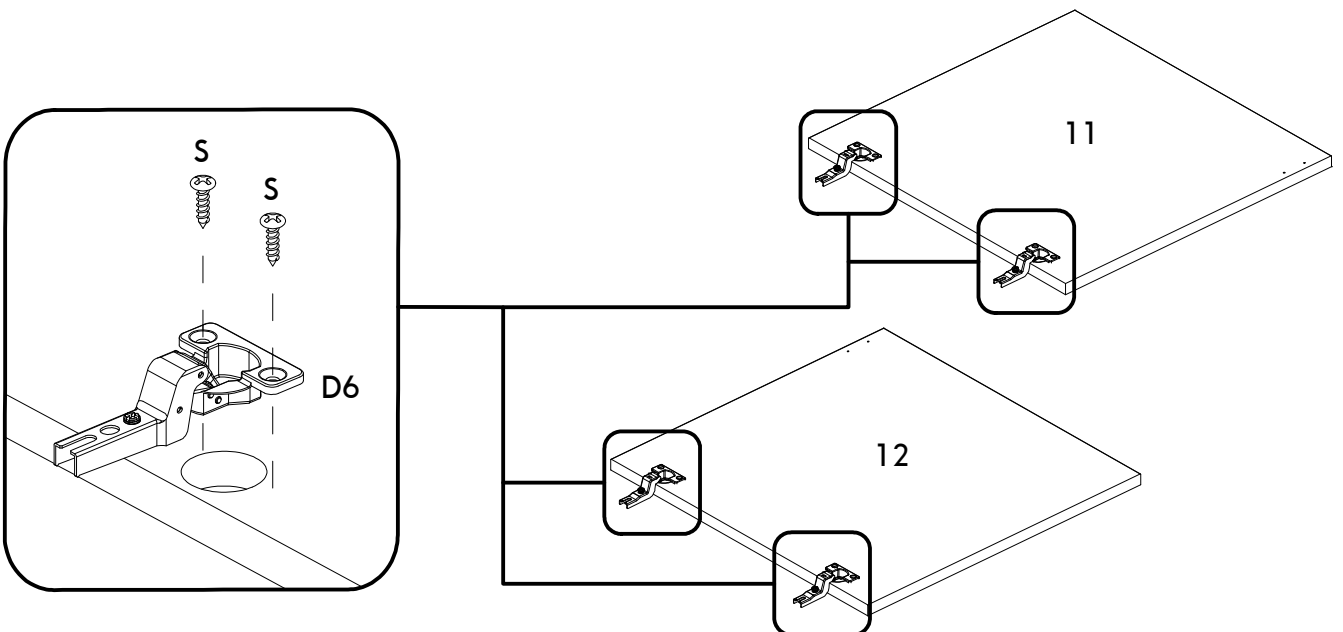

04

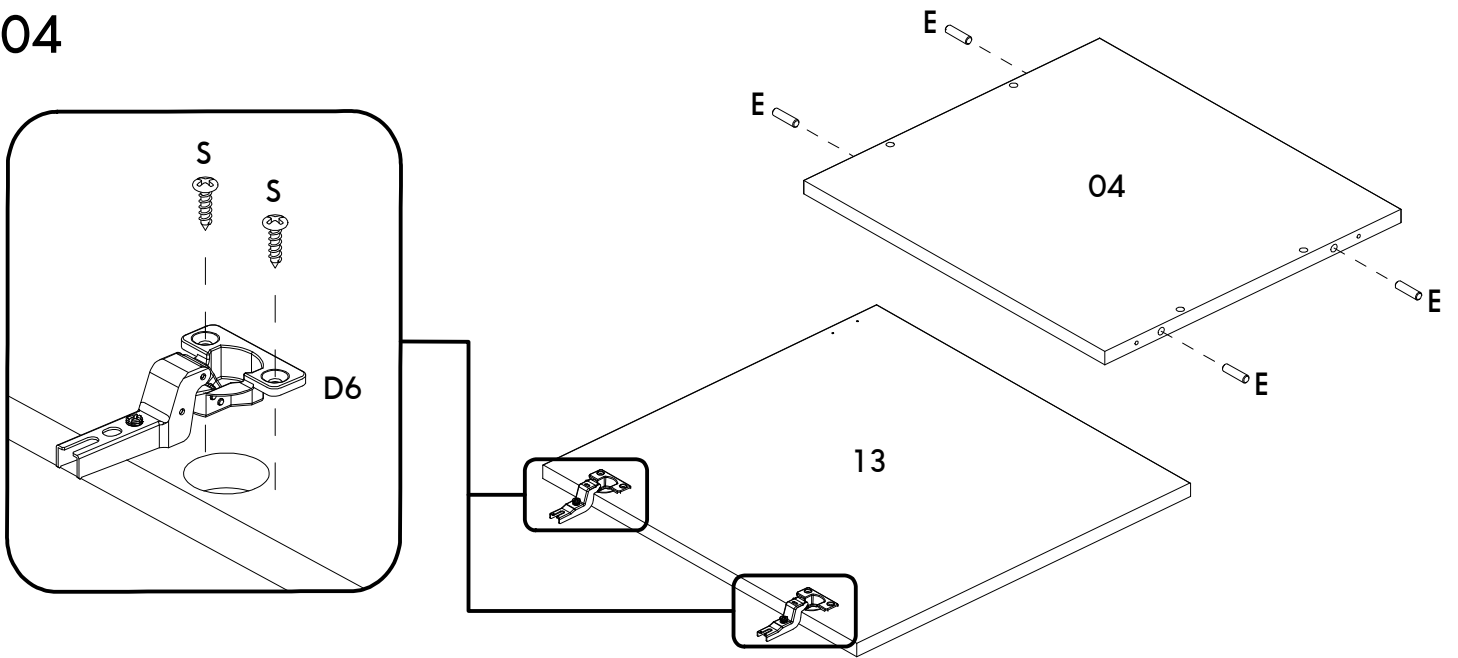

05

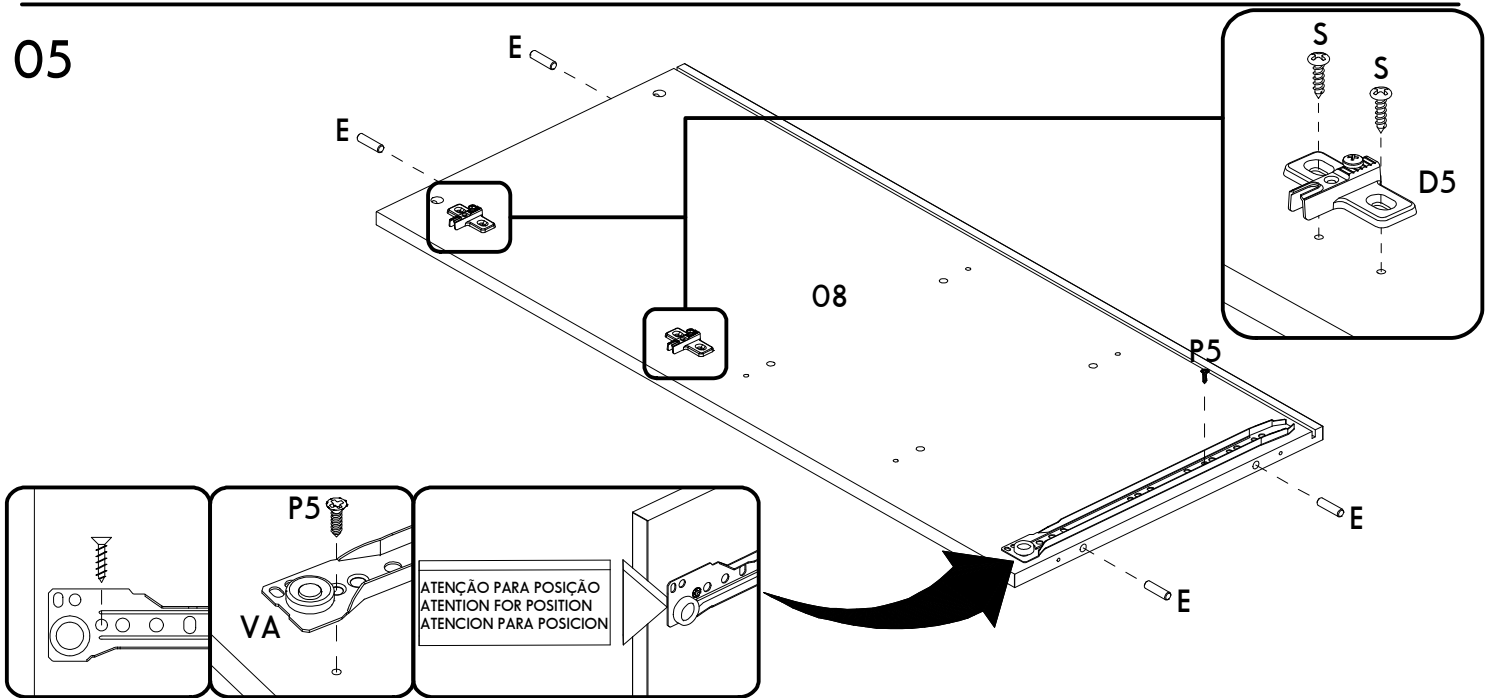

06

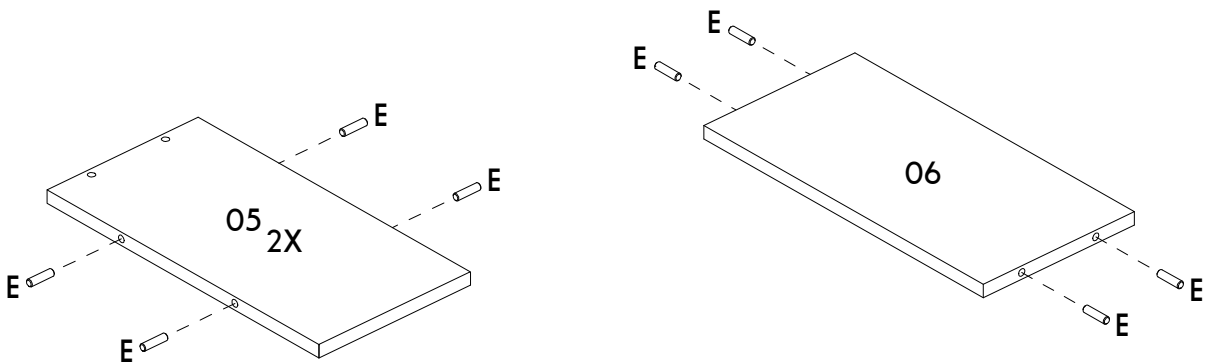

07

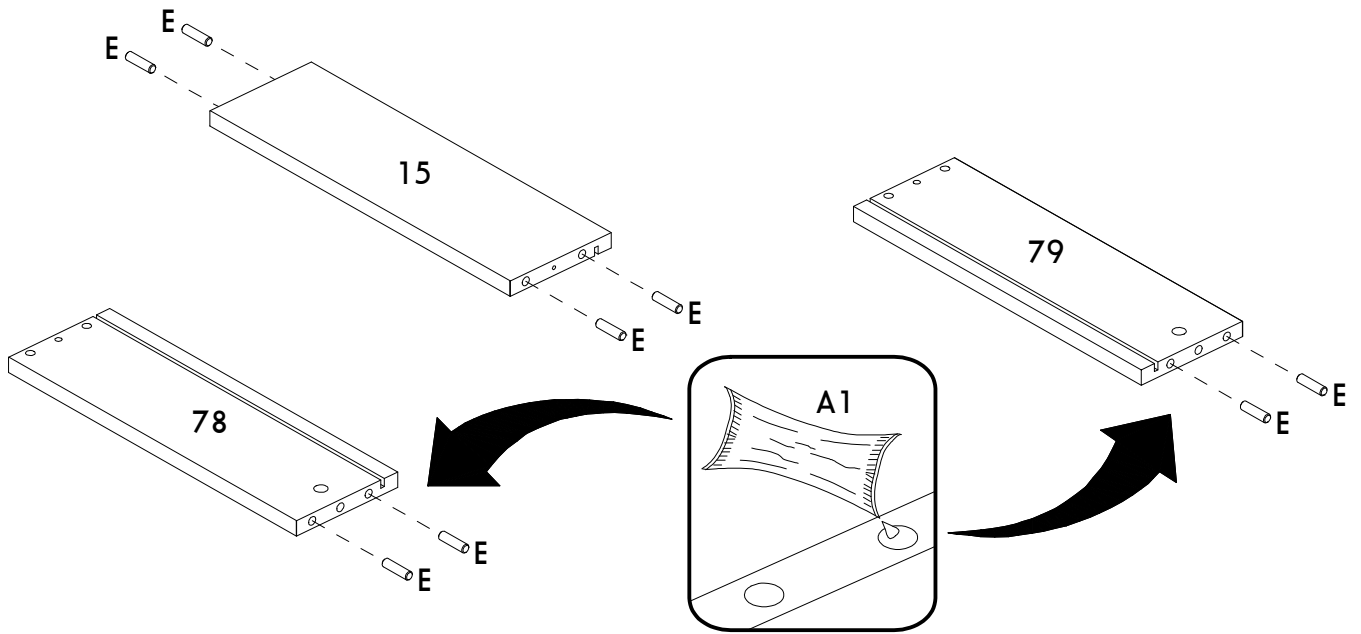

08

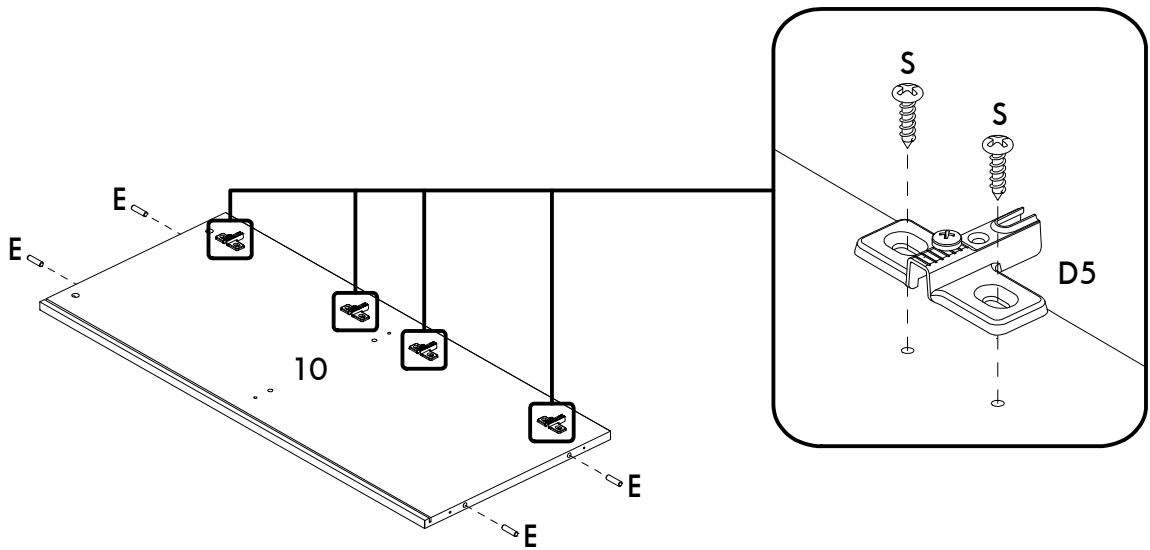

09

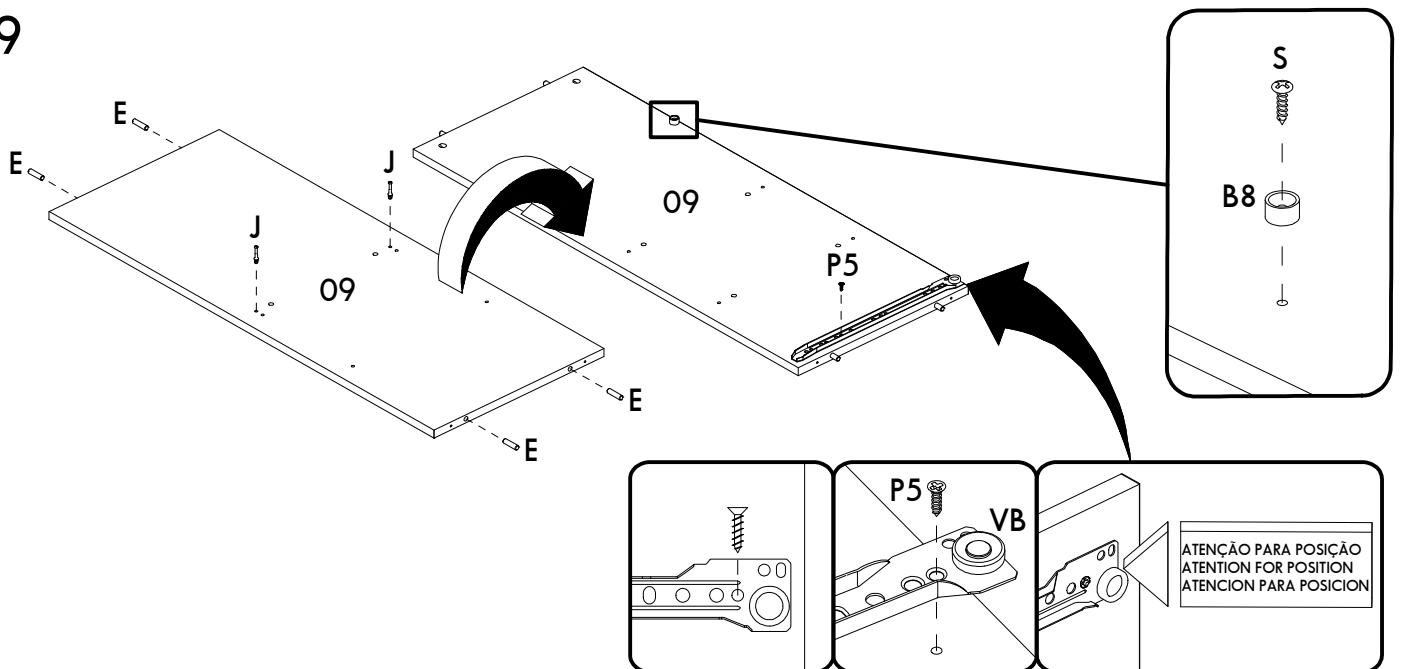

10

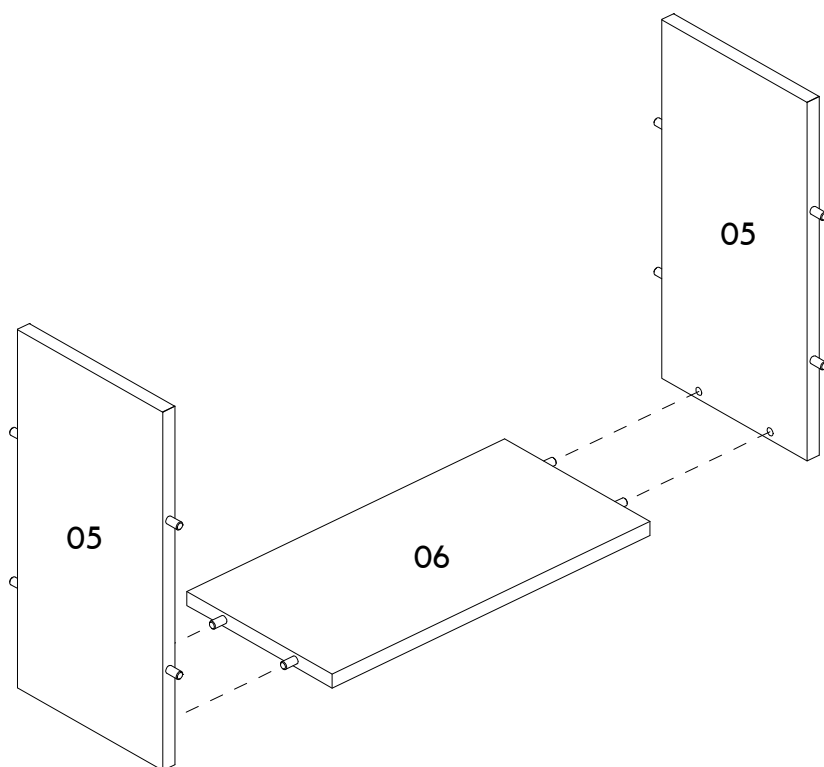

11

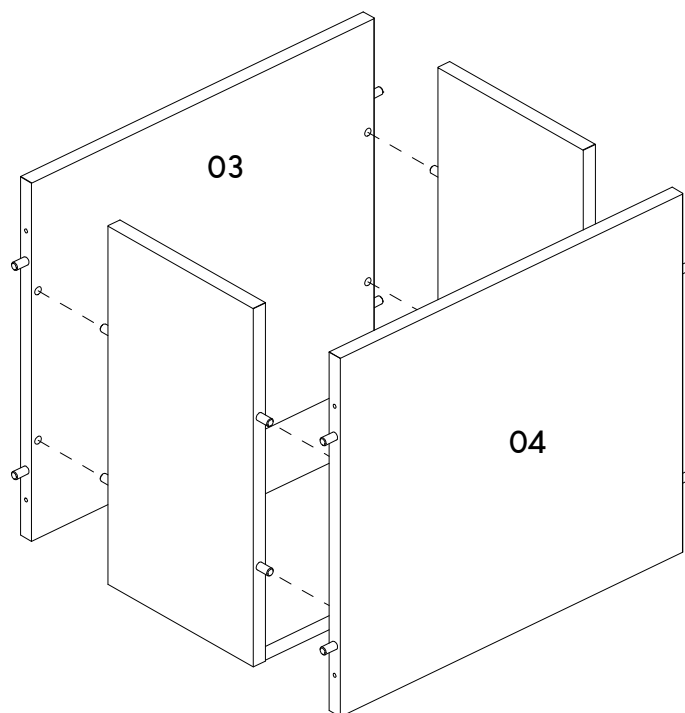

12

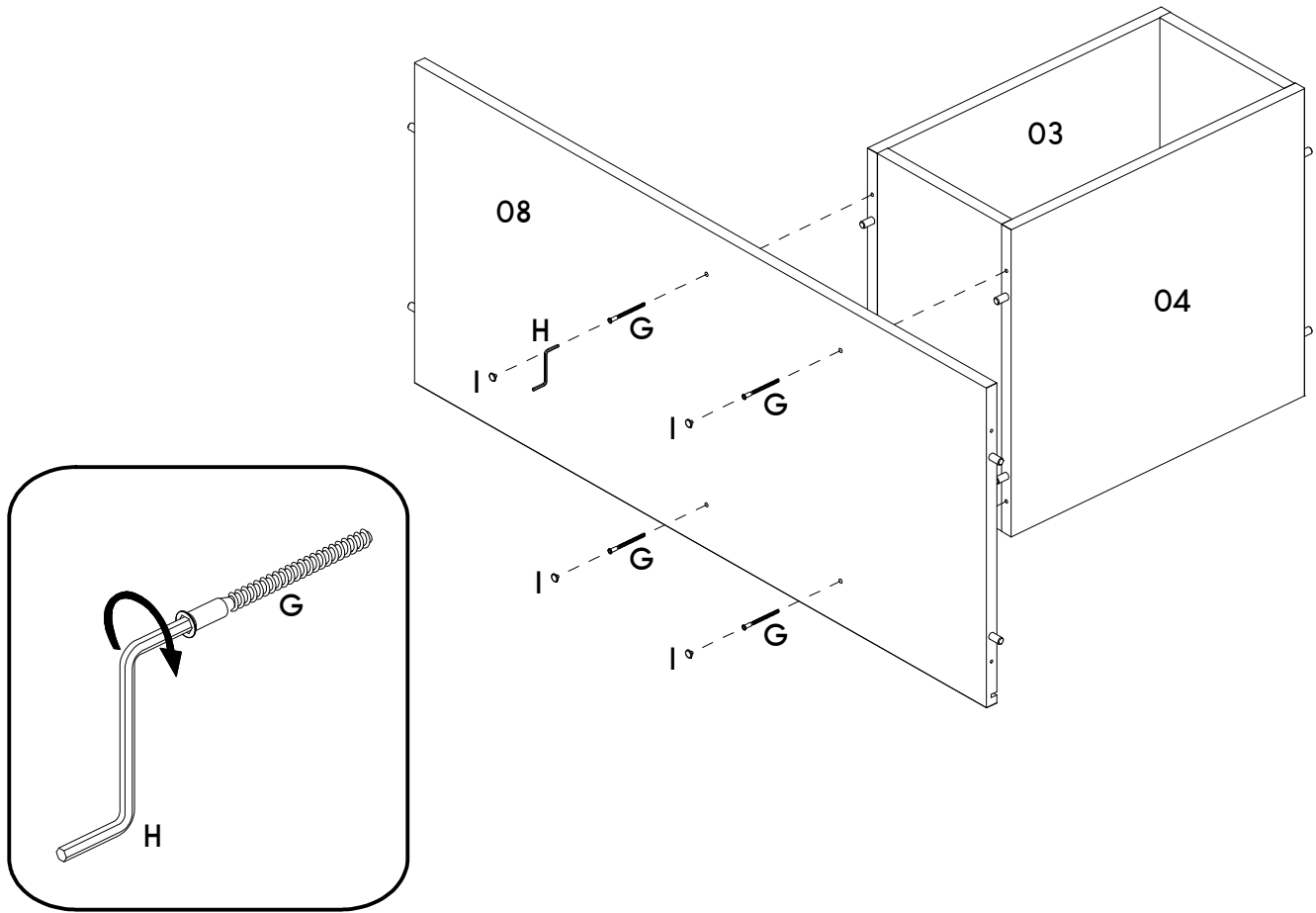

13

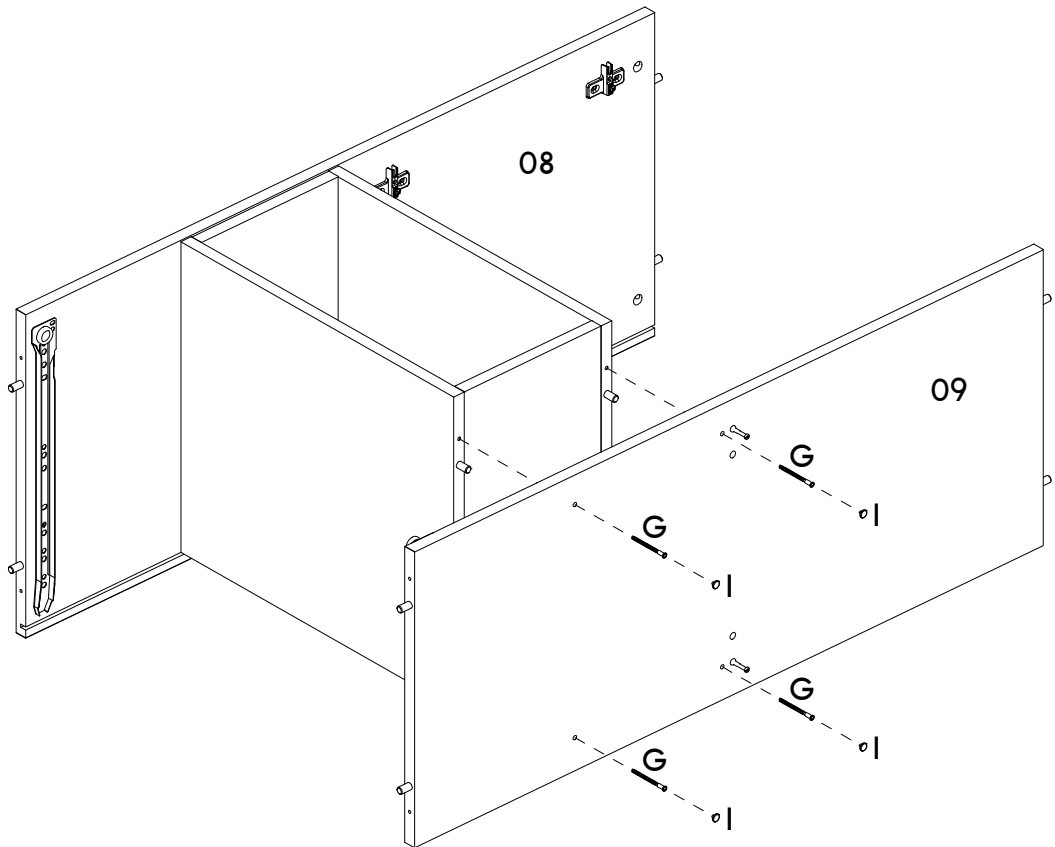

14

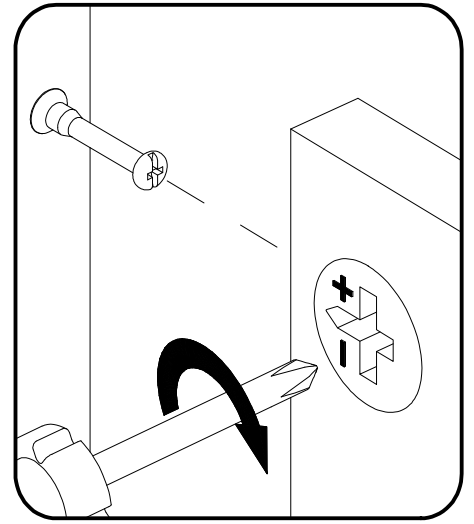
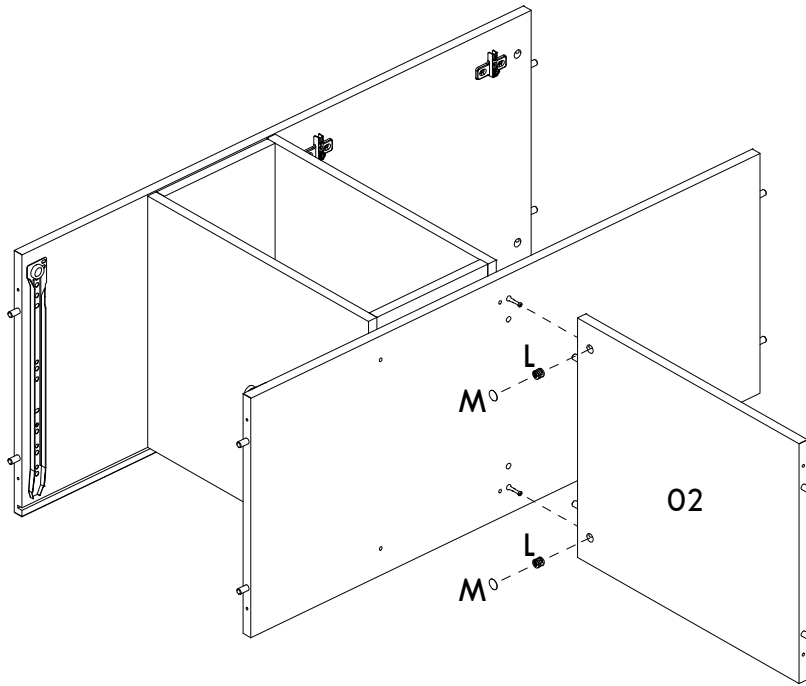

15

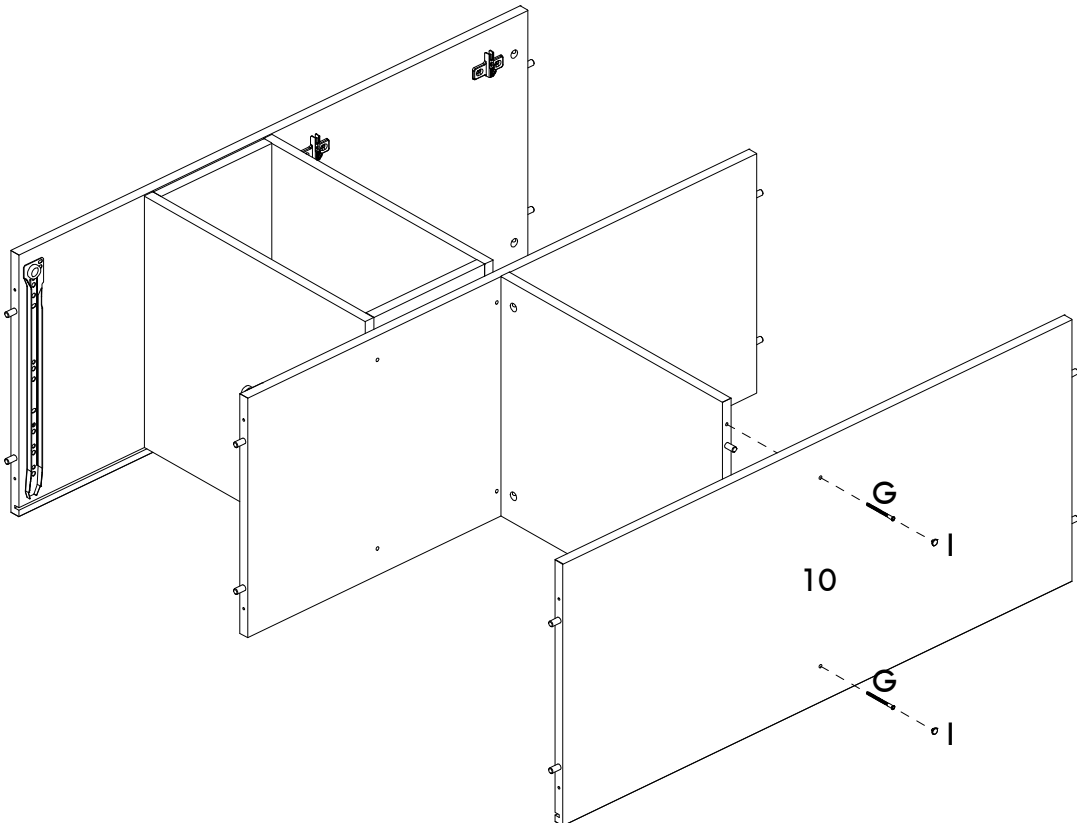

16

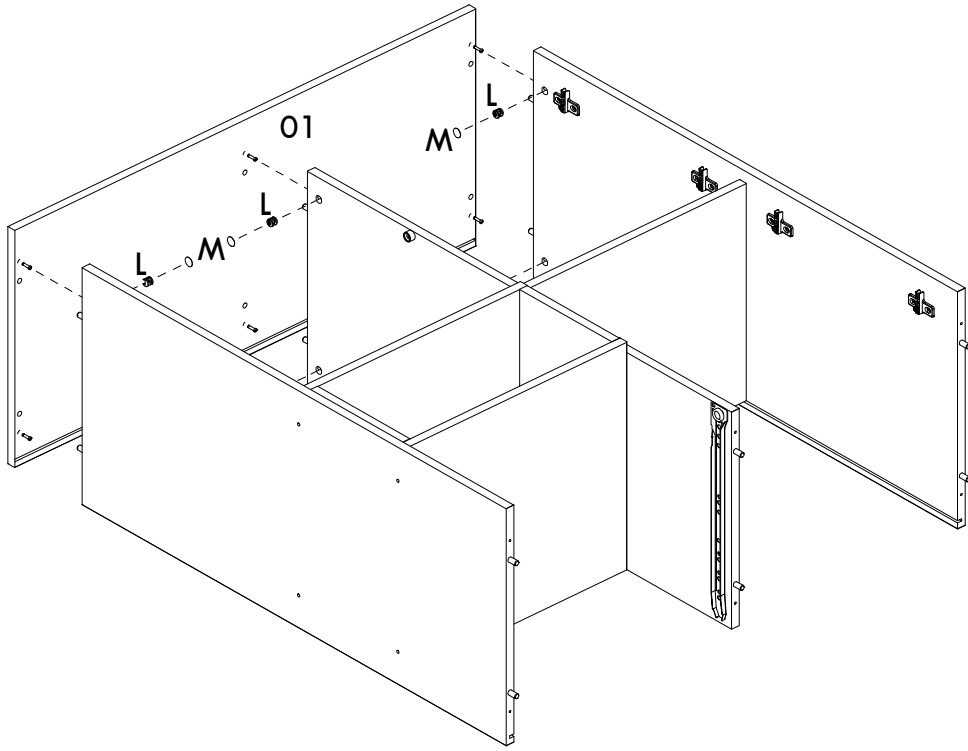

17

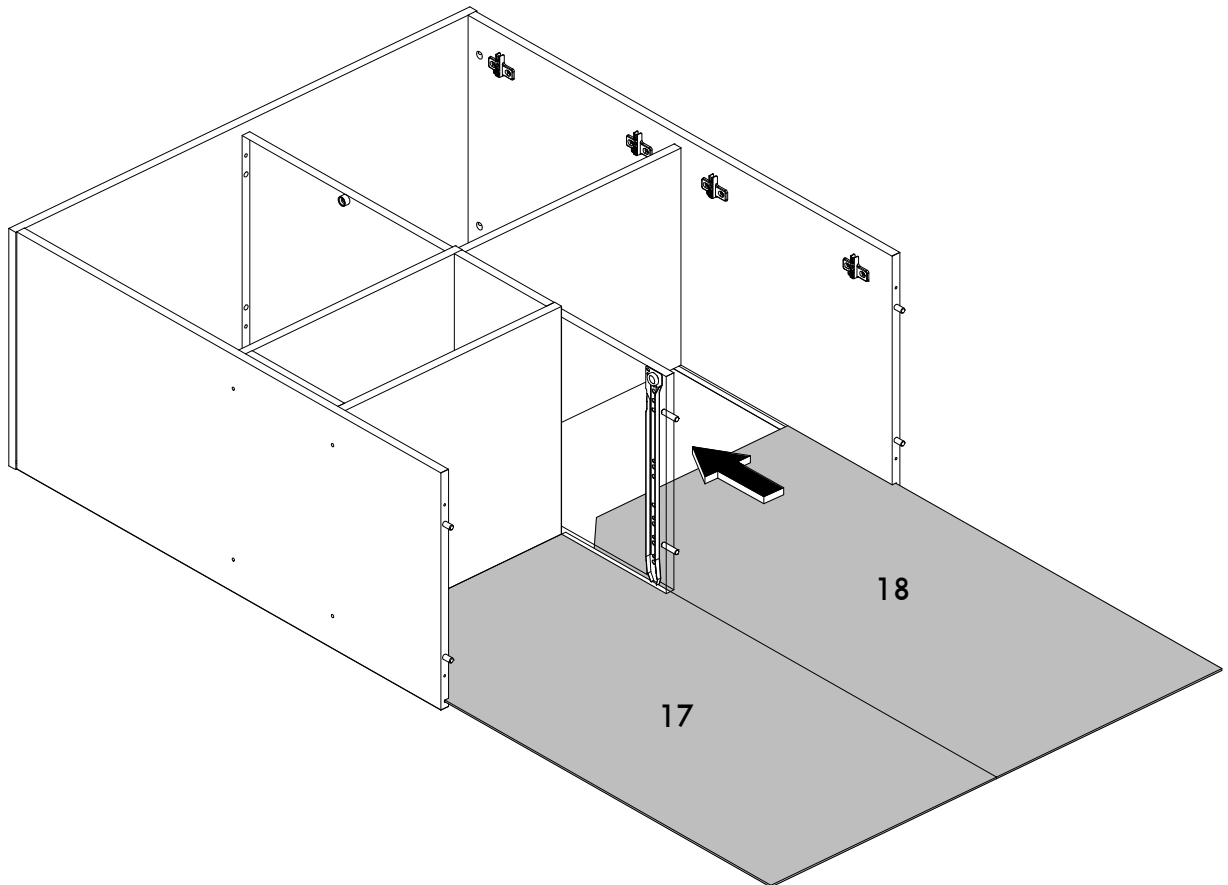

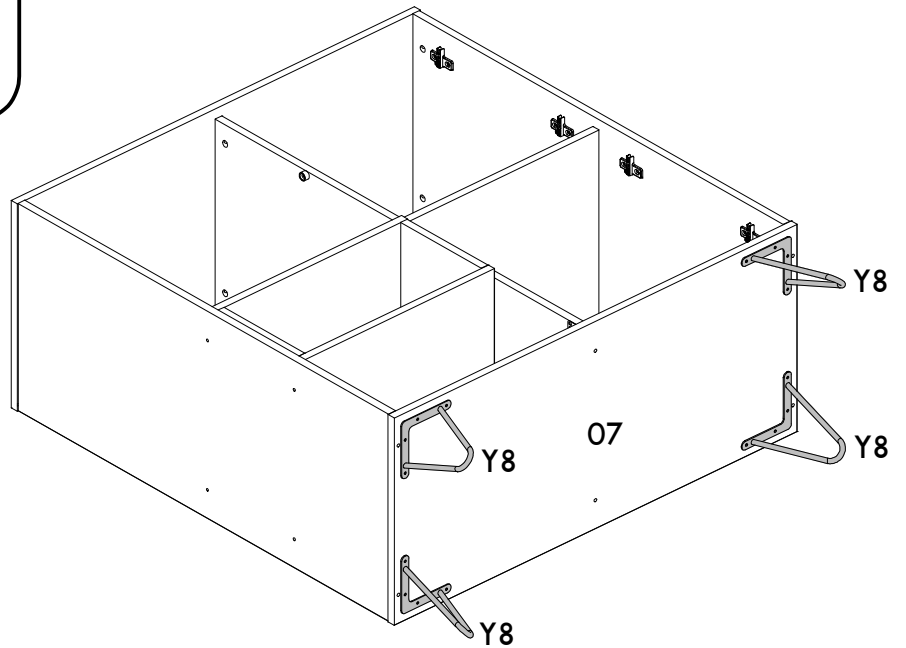
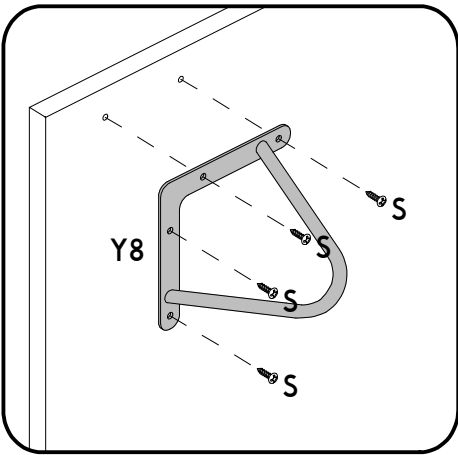
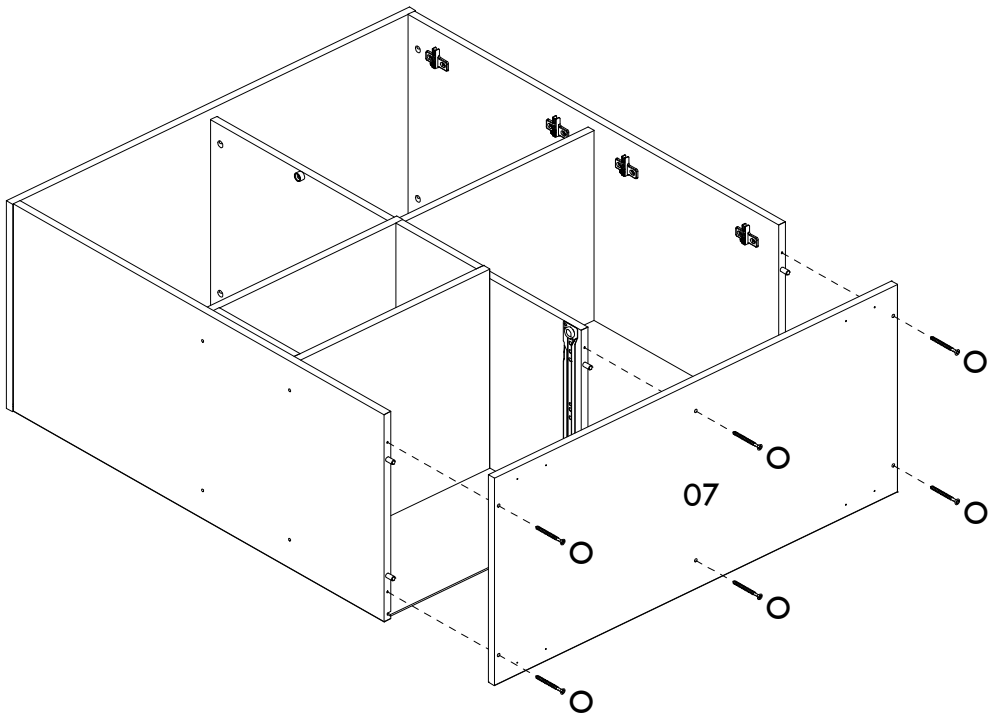

20

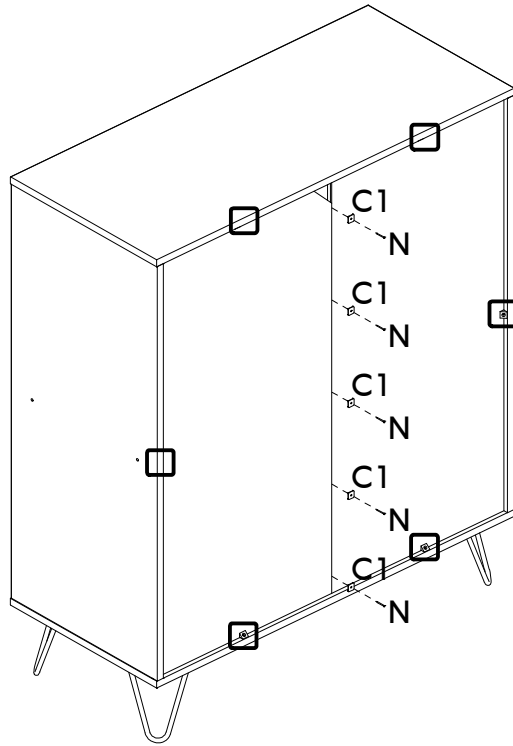

1º

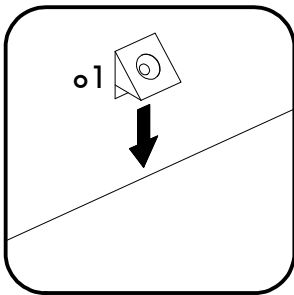

2º

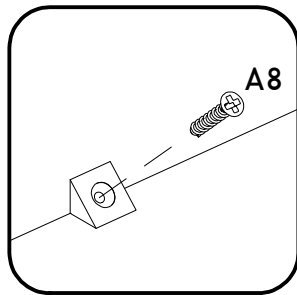

21

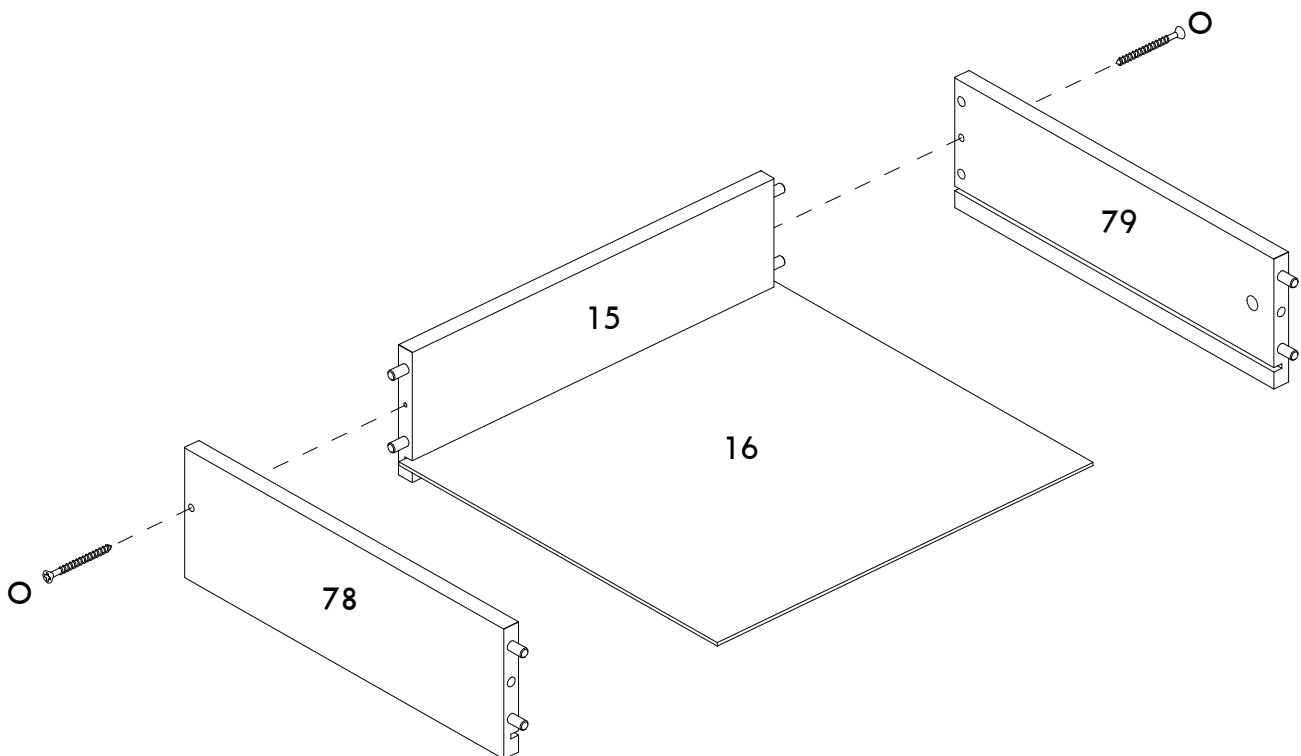

22

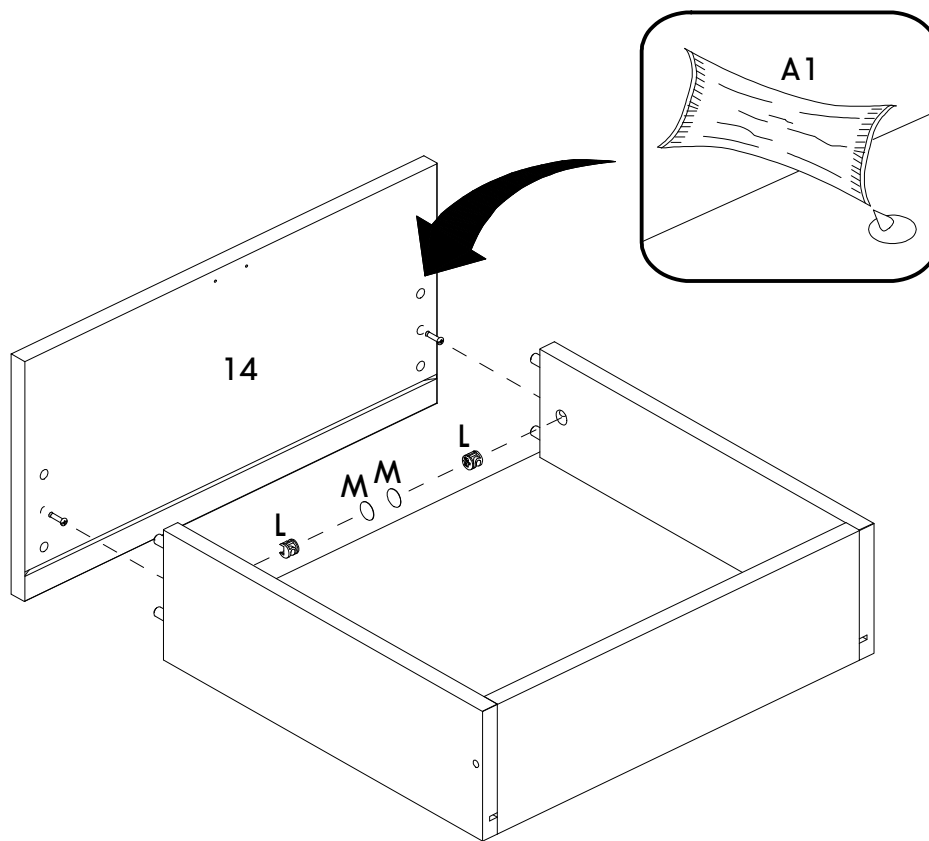

23

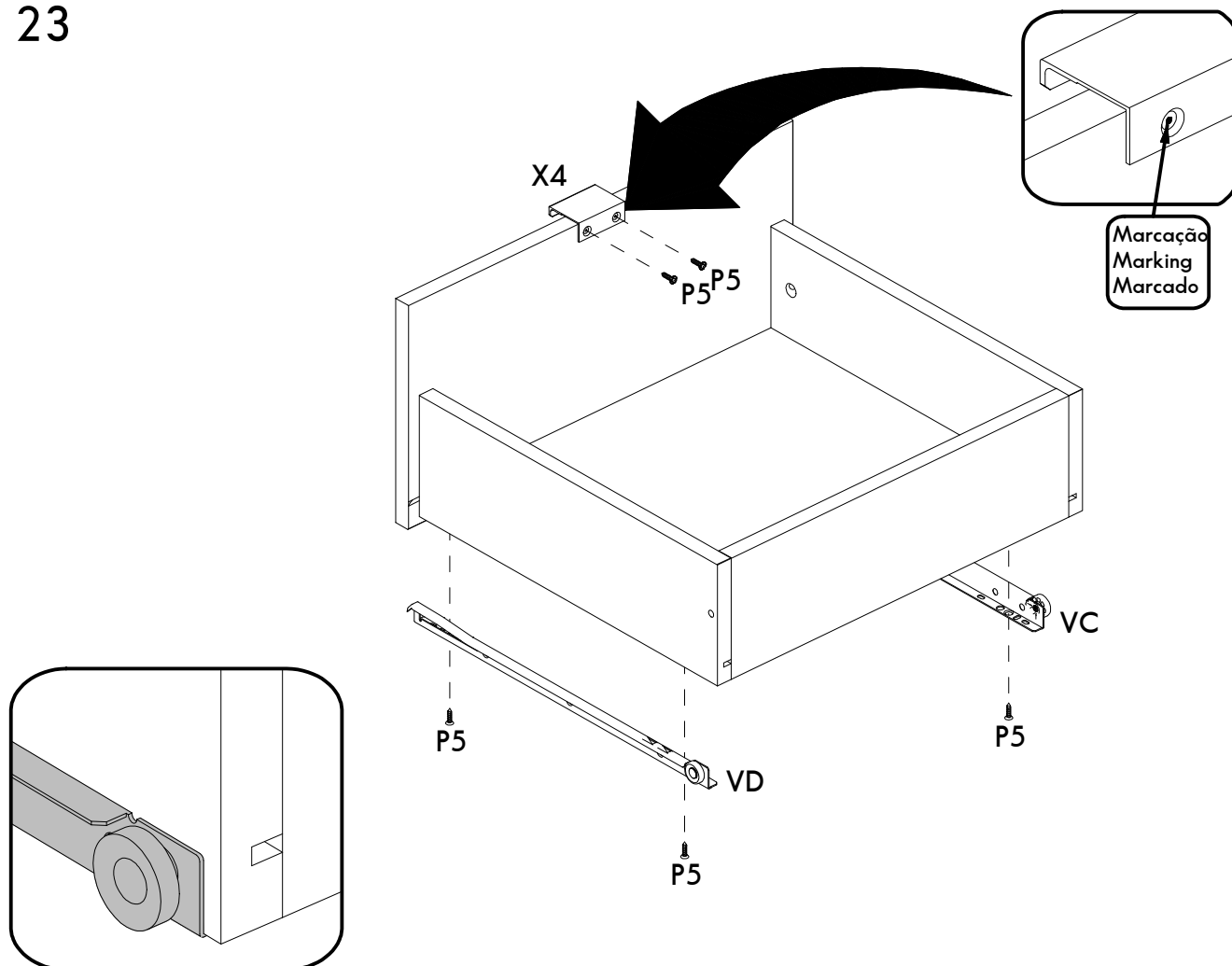

24

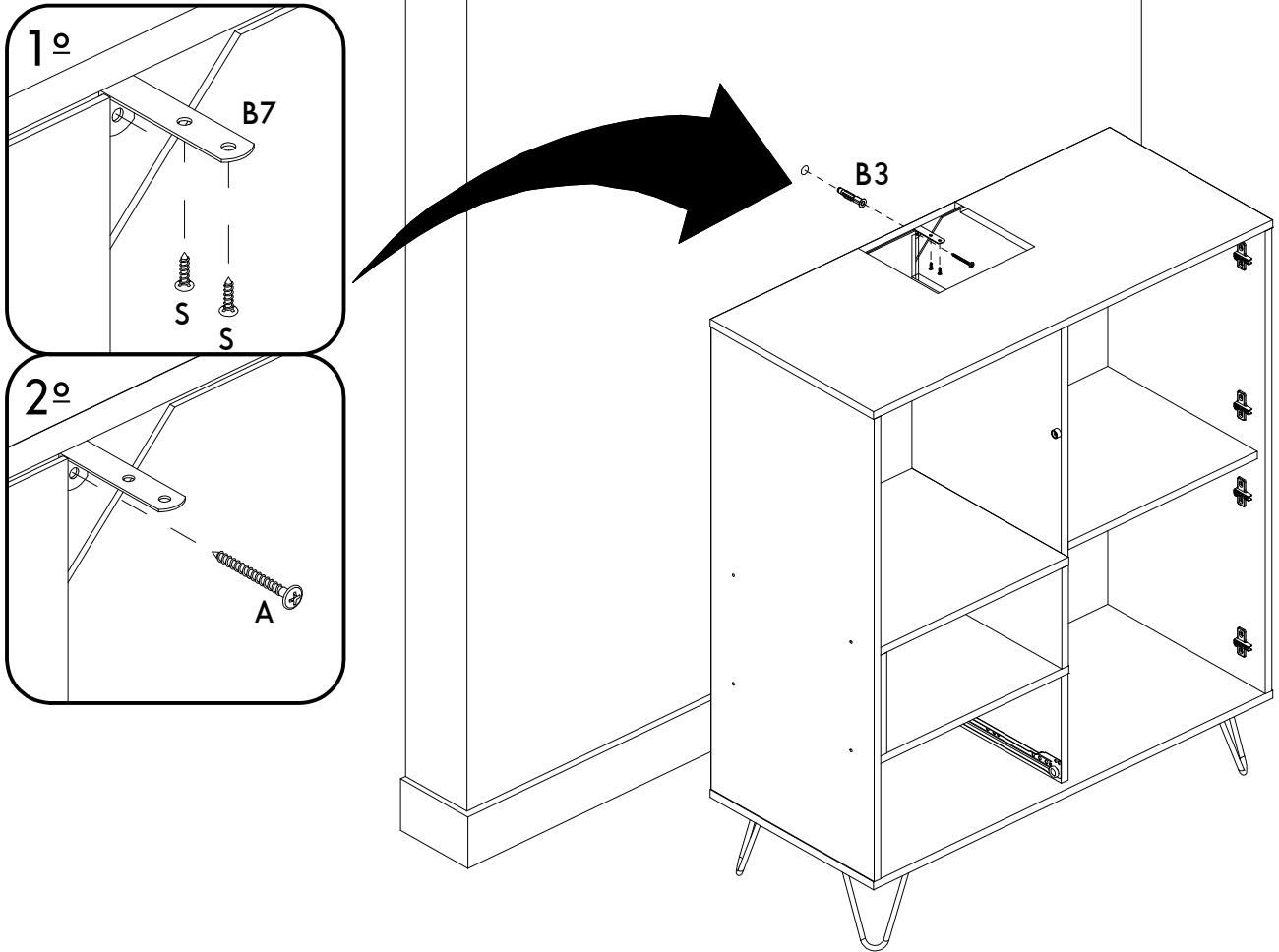

25

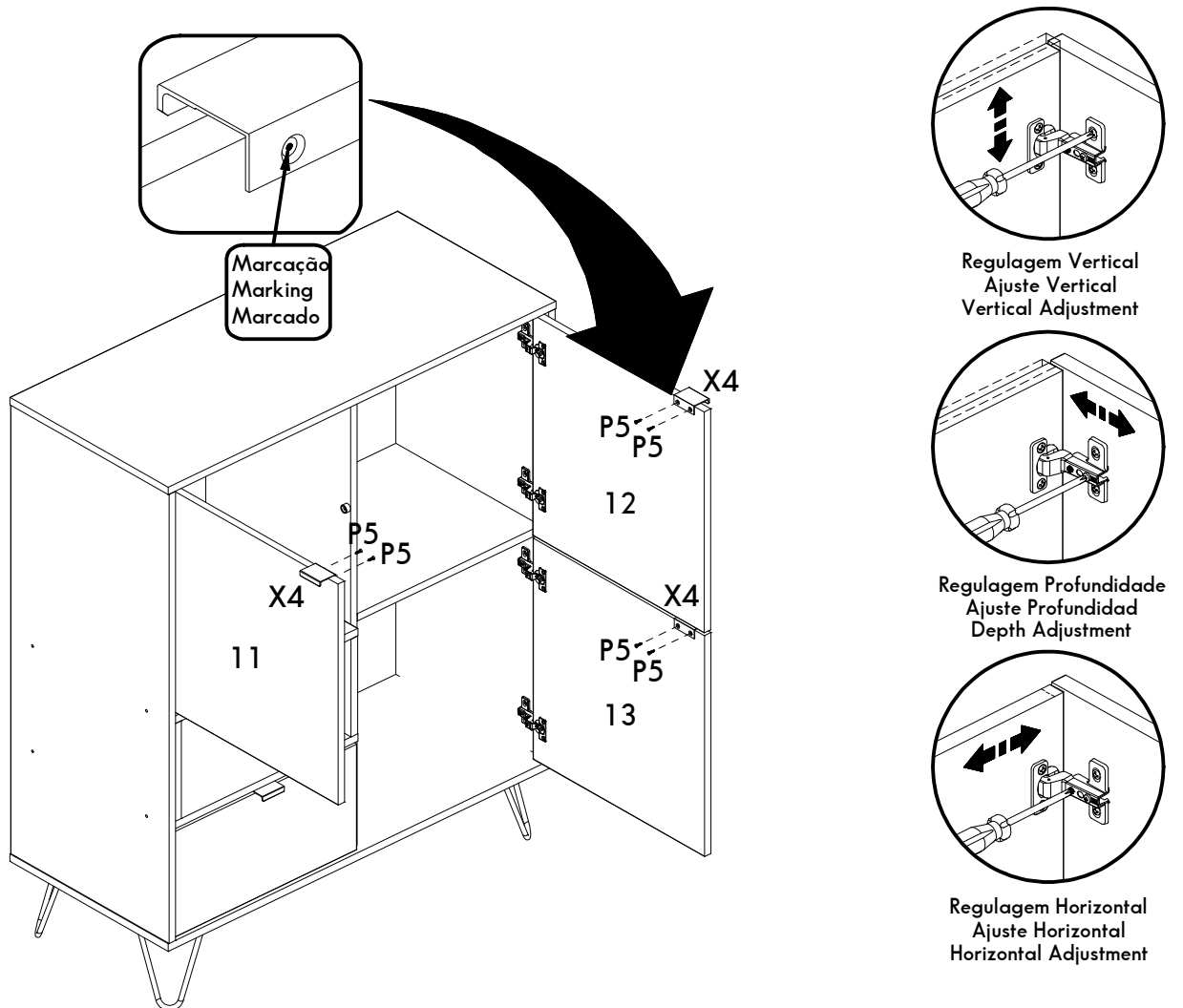

PESO MÁXIMO RECOMENDADO SENDO ESTE DISTRIBUÍDO UNIFORMEMENTE
MAXIMUM RECOMMENDED WEIGHT BEING THIS EVENLY DISTRIBUTED / PESO MÁXIMO RECOMENDADO SIENDO ESTE UNIFORMEMENTE DISTRIBUIDO

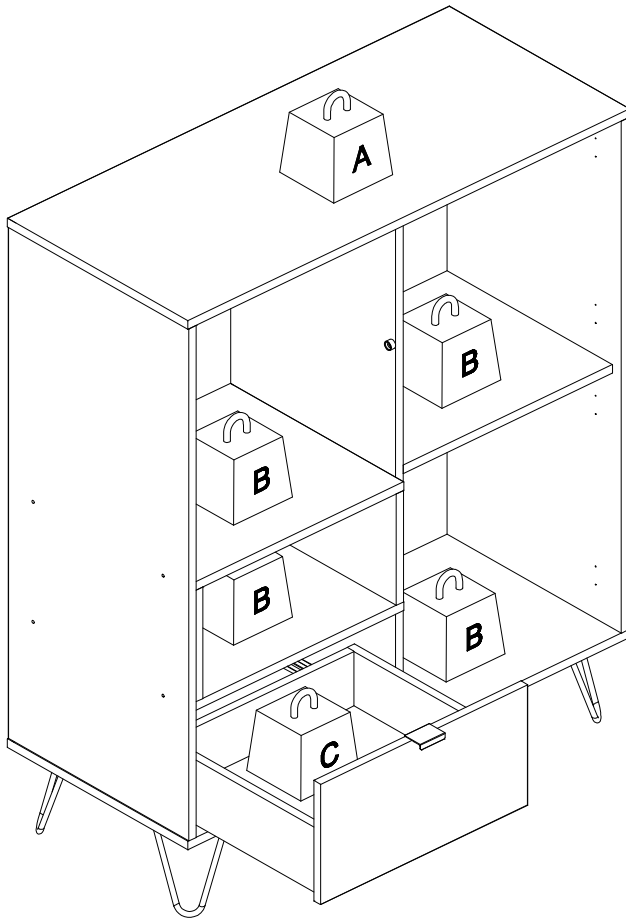

	KG	LB
A	15	33
B	5	11
C	3	6,6