

ASSEMBLY INSTRUCTIONS MANUAL DE MONTAGEM / INSTRUCCIONES DE ARMADO

CAJAMAR HIGH SHOE CABINET
SAPATEIRA CAJAMAR ALTA
ZAPATO CAJAMAR ALTO

Reference
Referência
Referencia

220561

| Revise
| Revisão
| Revisión

00



ENGLISH
PORTUGUÊS
ESPAÑOL

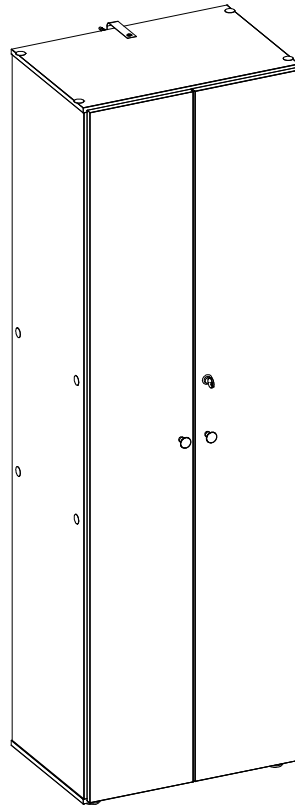

MAXIMUM RECOMMENDED WEIGHT
BEING THIS EVENLY DISTRIBUTED.

PESO MÁXIMO RECOMENDADO SENDO
ESTE DISTRIBUÍDO UNIFORMEMENTE.

PESO MÁXIMO RECOMENDADO SIENDO
ESTE UNIFORMEMENTE DISTRIBUIDO.

	LB	KG
—		
F	22	10

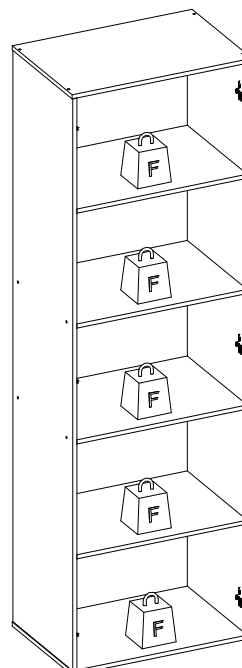

Nº	Measures_Inches	Medidas_cm	Qty./Qtd.
01	21 x 14 x 1/2	53.2 x 35.5 x 1.2	1
02	19 7/8 x 14 x 1/2	50.4 x 35.5 x 1.2	1
03	19 7/8 x 14 x 1/2	50.4 x 35.5 x 1.2	3
04	21 x 14 x 1/2	53.2 x 35.5 x 1.2	1
05	65 1/4 x 14 x 1/2	165.7 x 35.5 x 1.2	2
07	65 5/8 x 10 x 5/8	166.7 x 25.5 x 1.5	1
08	65 5/8 x 10 x 5/8	166.7 x 25.5 x 1.5	1
09	20 5/8 x 13 1/8 x 1/8	52.4 x 33.4 x 0.3	5

PARTS IDENTIFICATION IDENTIFICAÇÃO DAS PEÇAS / IDENTIFICACIÓN DE LAS PIEZAS

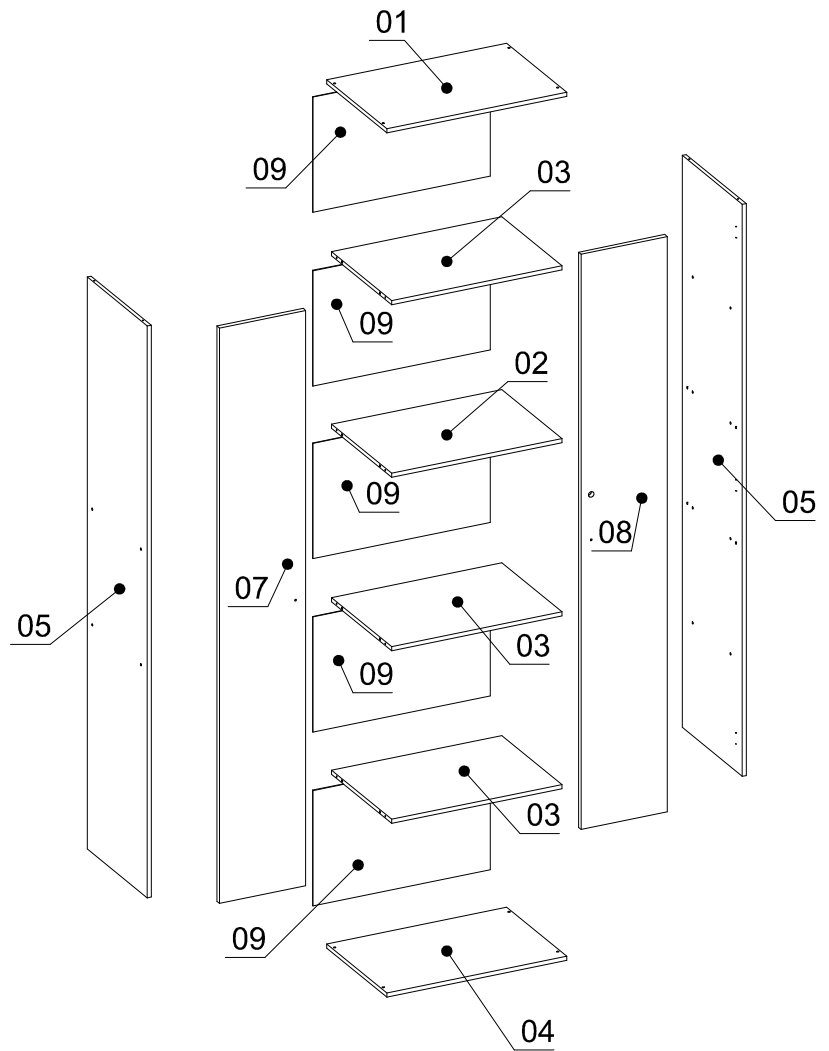

YOU WILL NEED / VOCÊ VAI PRECISAR DE / USTED NECESITARÁ

Tools not supplied / Ferramentas não fornecidas / Herramientas no incluidas

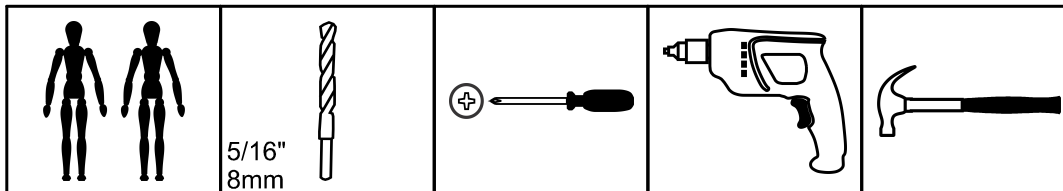

2 People
2 Pessoas
2 Personas

5/16"
8mm
Drill bit
Broca
Taladro

Screwdriver Phillips
Chave Phillips
Destornillador cruz

Drill machine
Furadeira
Taladro

Hammer
Martelo
Martillo











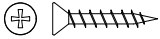
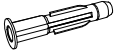





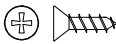

The separation of the accessories before you start the assembly will facilitate the same. In case of doubt on the size of the screws and bolts, use the ruler to bottom of page 3.

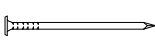
A separação dos acessórios antes de iniciar a montagem facilitará a mesma. Em caso de dúvida no tamanho dos parafusos e cavilhas, utilize a régua ao final da página 3.

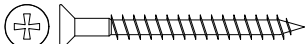
La separación de los accesorios antes de comenzar el armado facilitará el mismo. En caso de duda sobre el tamaño de los tornillos y taquetes, utilice la regla al pie de página 3.

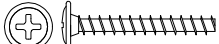
IDENTIFICATION OF ACCESSORIES IDENTIFICAÇÃO DOS ACESSÓRIOS/ IDENTIFICACIÓN DE ACCESORIOS

A		Flanged head screw / Parafuso flangeado / Tornillo de cabeza flangeada	5,0x60 mm	1
A8		Flat head screw / Parafuso chato / Tornillo de cabeza plana	3,5x20 mm	4
B3		Bushing / Bucha expansiva / Tapón	8x50 mm	1
C1		Metal claw / Garra de metal / Garra metal	-	8
D5		Hinge shim / Calço dobradiça / Bisagra de calce	-	6
E9		Strap / Cinta / Correa	-	1
F1		Wooden dowel / Cavilha / Taquete	6x30 mm	16
F6		Metal hinge curve / Dobradiça curva / Esquina de bisagra metálica	26 mm	6
F17		Door stop / Batente de porta / Tope de puerta	-	1
G2		Door stop / Batente de porta / Tope de puerta	-	1
L4		Plastic foot / Sapata / Pie plástico	38x17 mm	4
L9		Flat head screw / Parafuso chato / Tornillo de cabeza plana	3,5x12 mm	29
M		Bore patch adhesive / Tapa furo adesivo / Tapones adhesivo	-	12
N		Nail / Prego / Clavo	10x10	55
N14		Lock / Fechadura/ Cerradura	15 mm	1
O		Flat head screw / Parafuso chato / Tornillo de cabeza plana	4,5x45 mm	16
o9		Flanged head screw / Parafuso flangeado / Tornillo de cabeza flangeada	3,5x16 mm	4
T		Flanged head screw / Parafuso flangeado / Tornillo de cabeza flangeada	3,5x25 mm	2
Z6		Handle / Puxador Dublin / Tirador	-	2



PRE-ASSEMBLE
PRÉ-MONTAGEM / PRE ARMADO

01

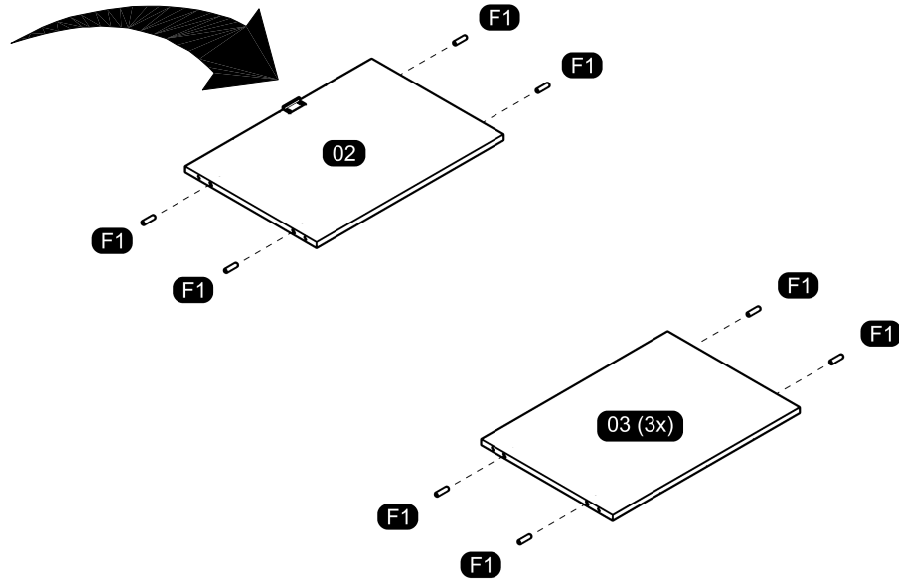
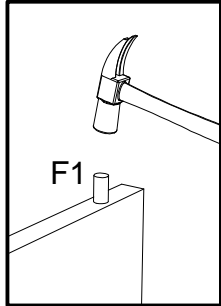
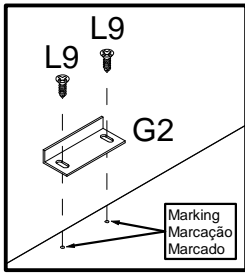

02

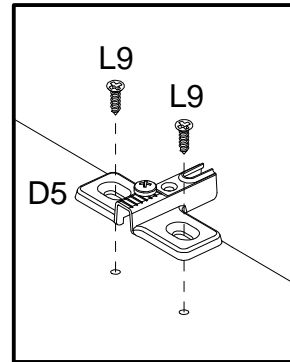
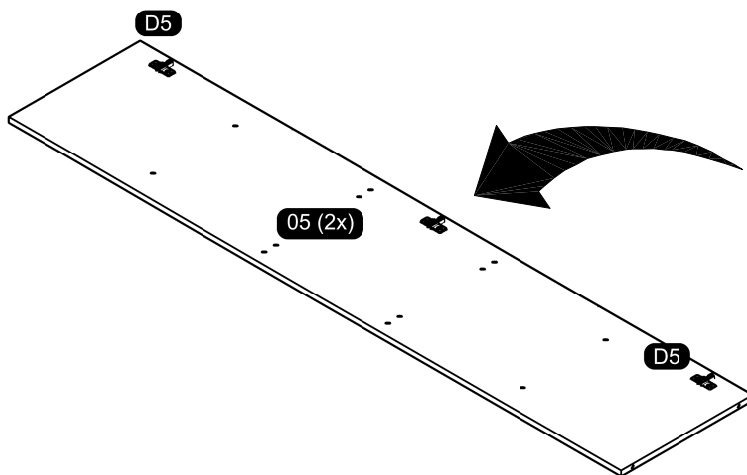

03

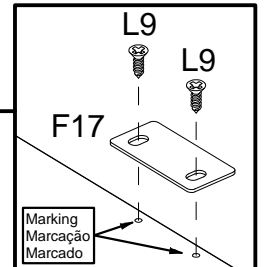
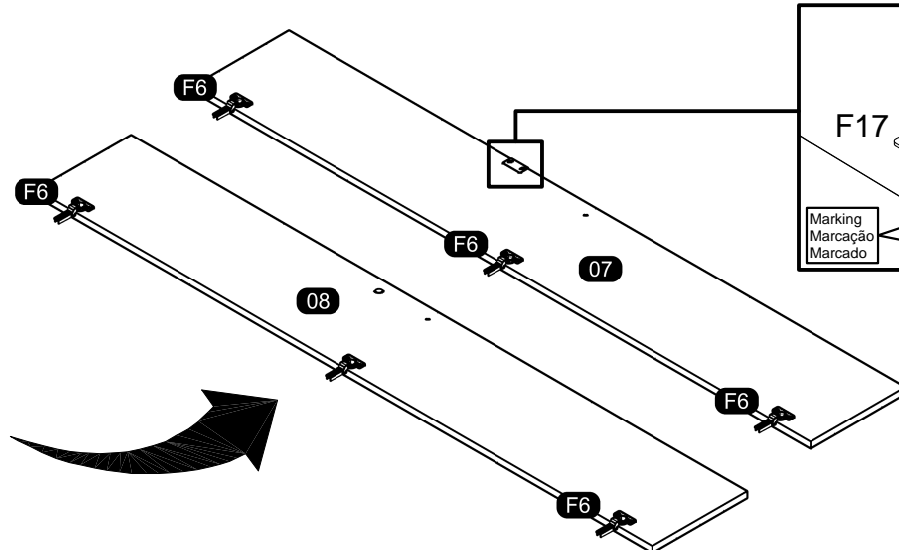
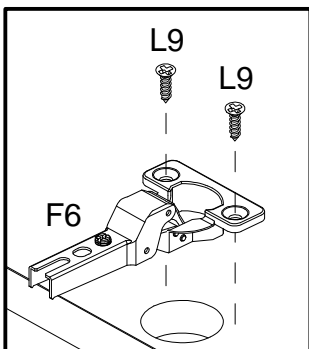

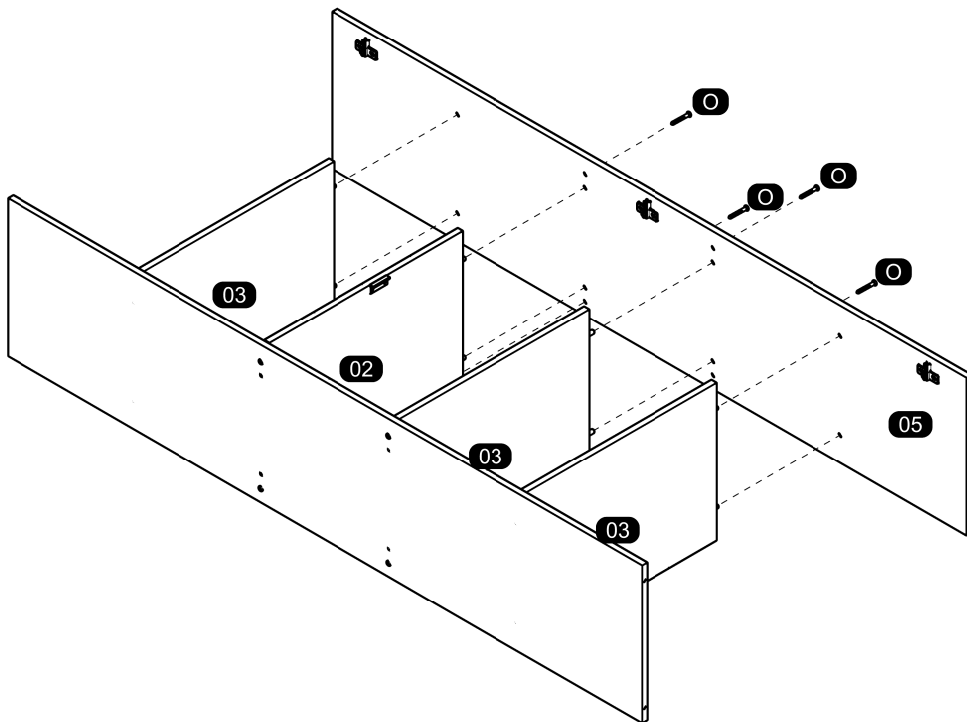
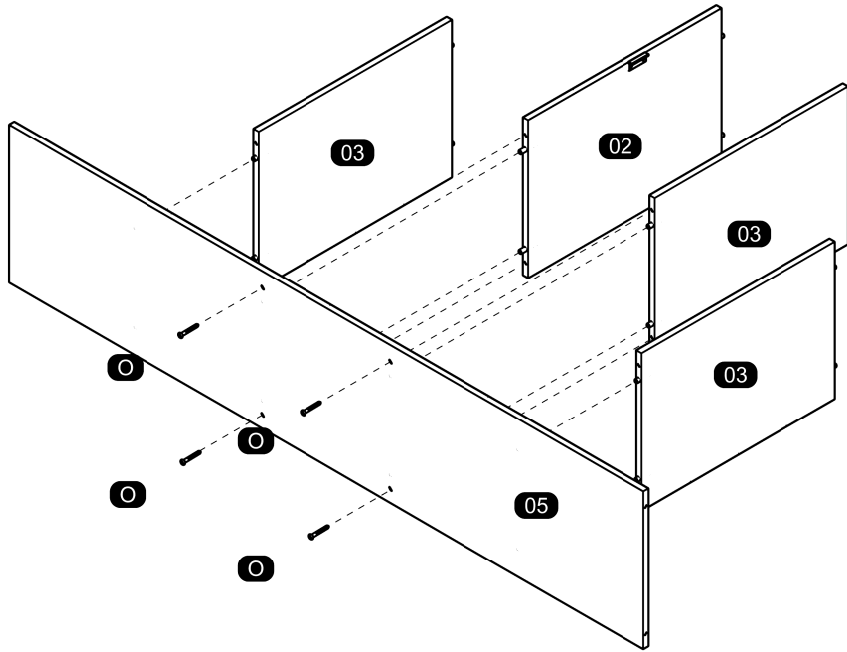

06

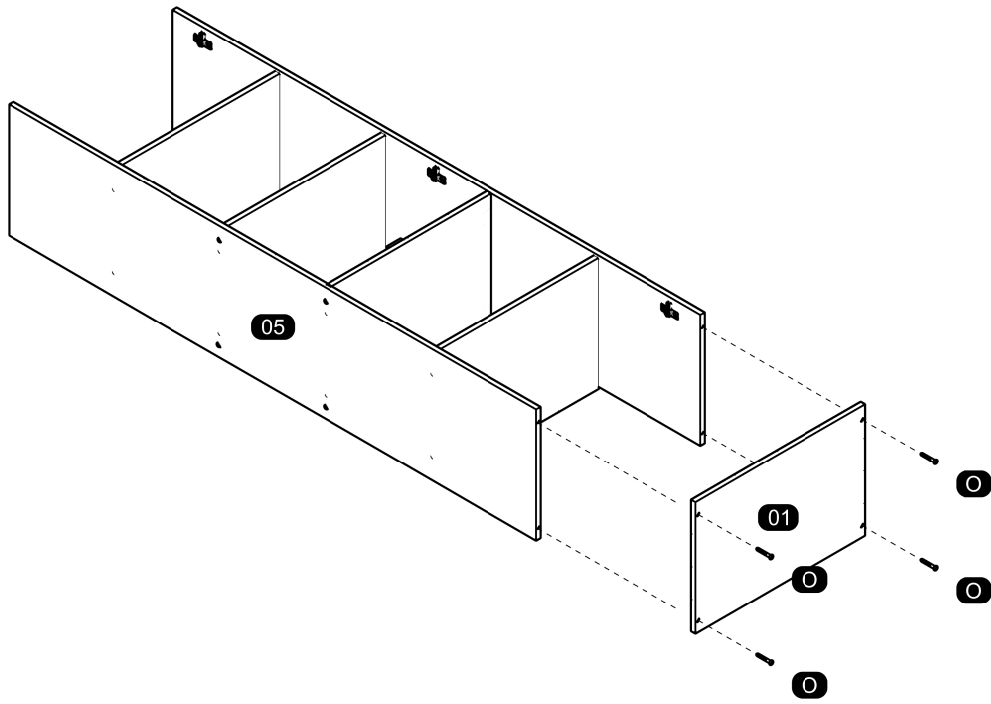

07

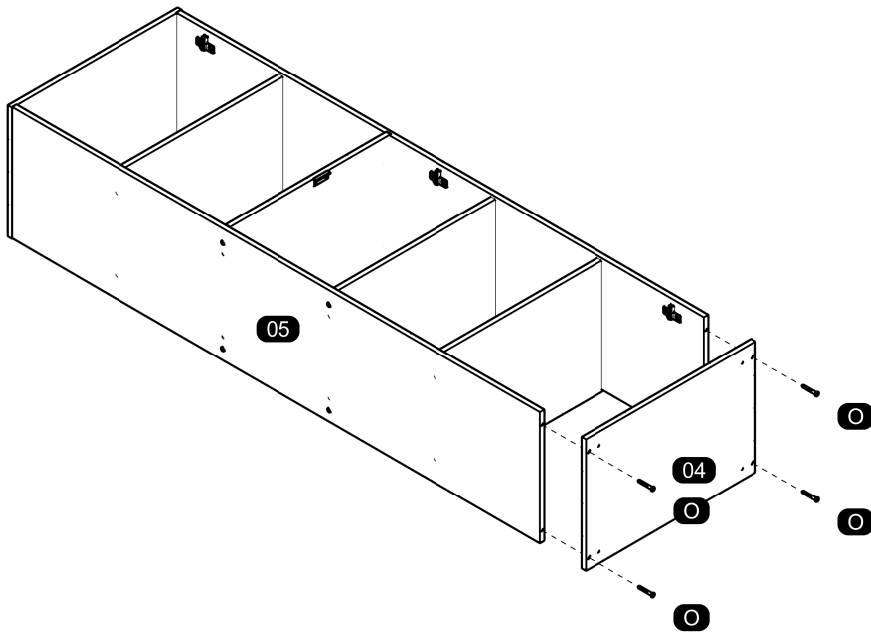

08

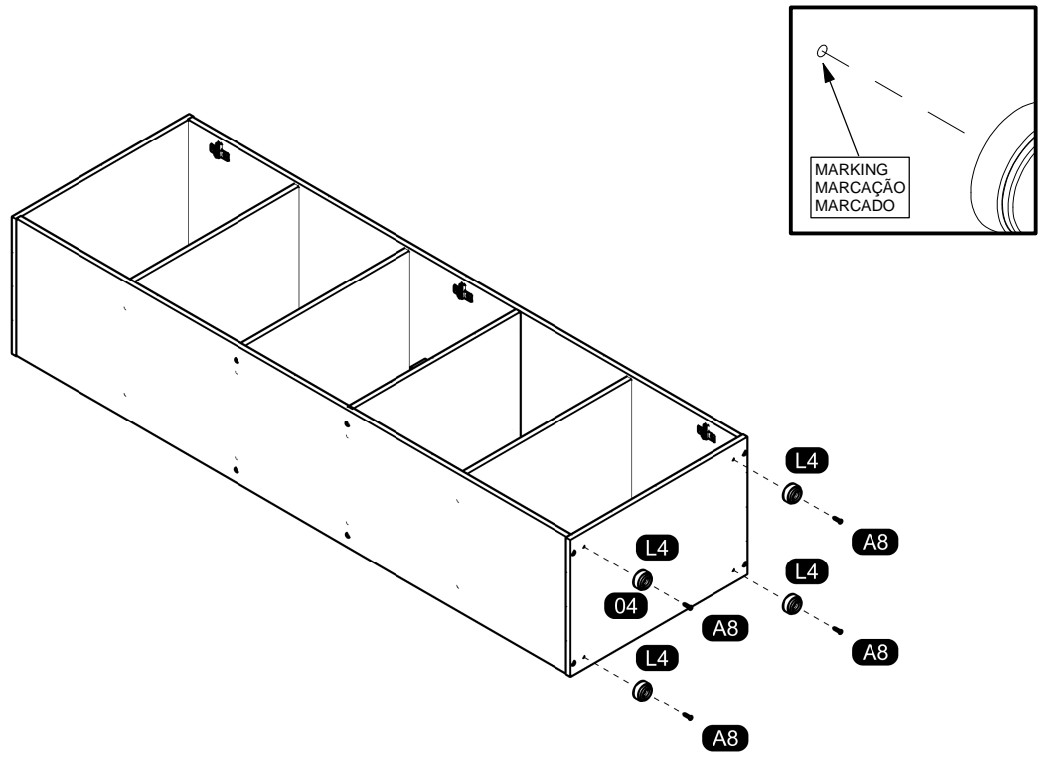

09

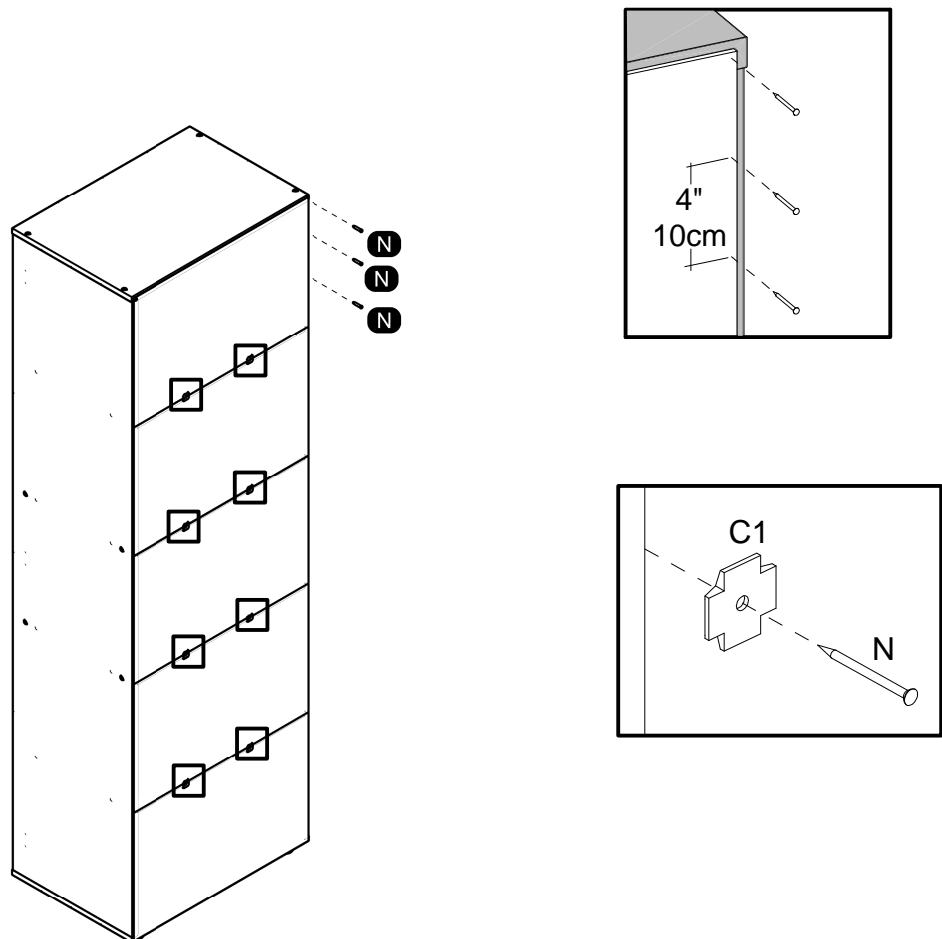

10

TO AVOID ANY INJURY THE FURNITURE MUST BE FIXED ON THE WALL. THANKS.
PARA EVITAR QUALQUER ACIDENTE, É OBRIGATÓRIO FIXAR O MÓVEL NA PAREDE. OBRIGADO!
PARA EVITAR CUALQUIER ACCIDENTE ES OBLIGATORIO ANCLAR EL MUEBLE EN LA PARED. GRACIAS.

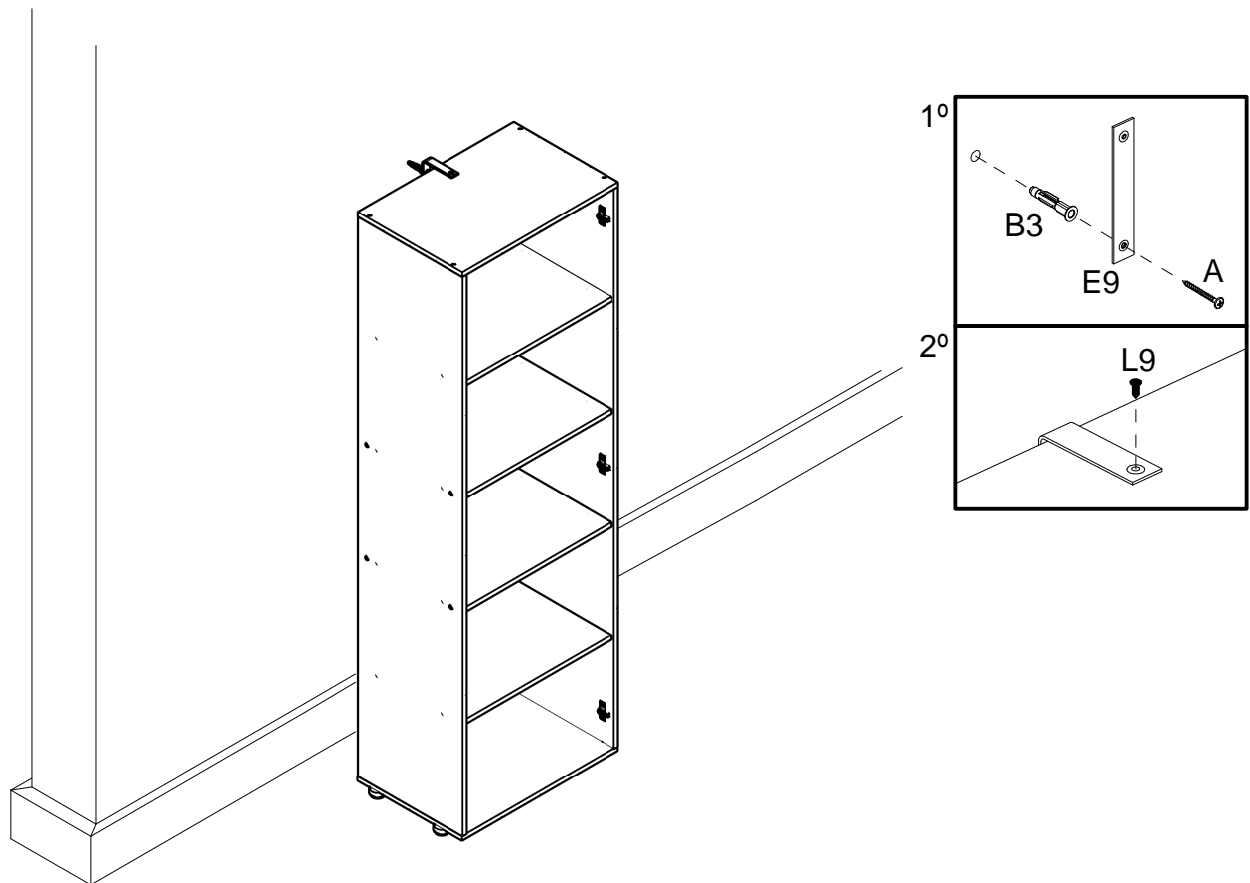

11

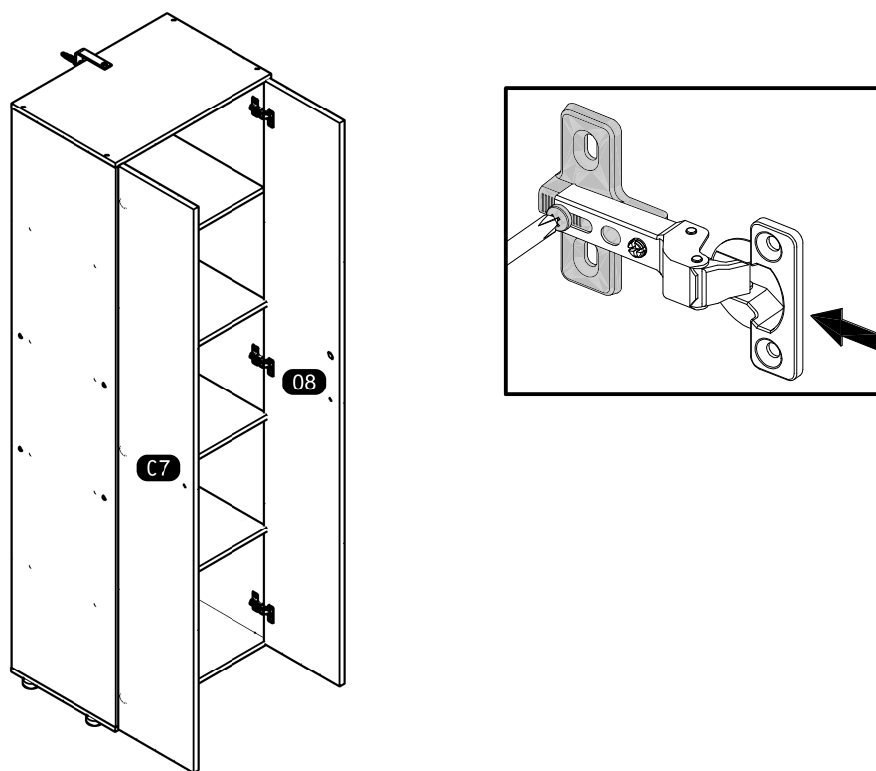

12

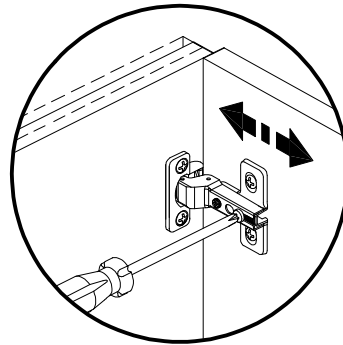
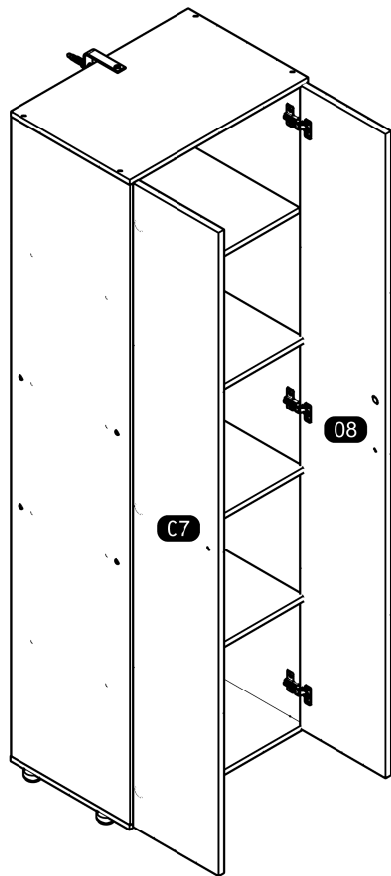

Depth Adjustment
Regulagem Profundidade
Ajuste Profundidad

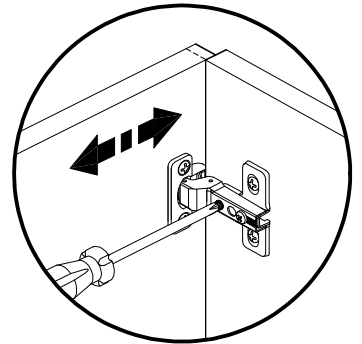

Horizontal Adjustment
Regulagem Horizontal
Ajuste Horizontal

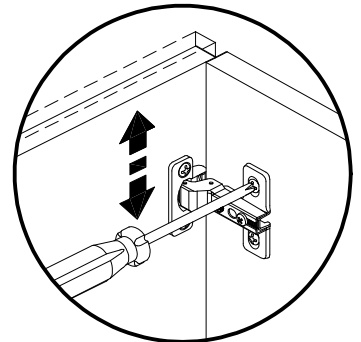

Vertical Adjustment
Regulagem Vertical
Ajuste Vertical

13

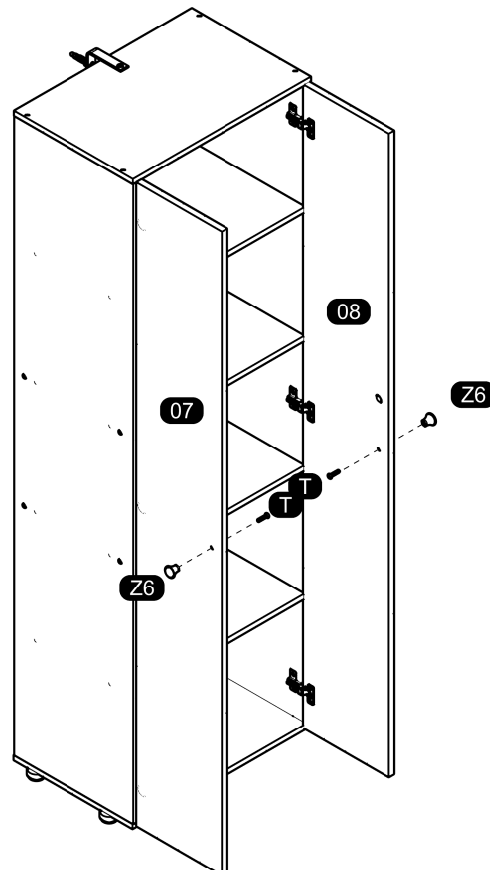

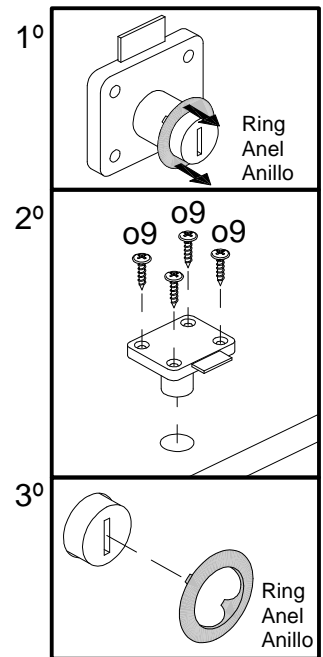
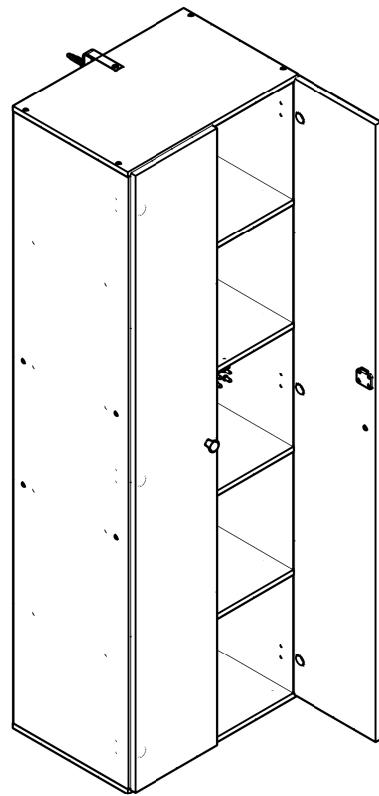

At the end of the assembly, insert the screw cover / hole plugs in the apparent holes.
 Ao final da montagem, insira a(s) tampa(s) de parafuso / tapa furos nos furos que ficarem aparentes.
 Al final del conjunto, coloque la tapa tornillo / tapón plástico en los agujeros que se hagan evidentes.

